

Manufactured Housing Rules

Effective: October 23, 2022

*Administrative Rules of the Texas Department of Housing and Community Affairs
10 Texas Administrative Code, Chapter 80*

TABLE OF CONTENTS

SUBCHAPTER A. CODES, STANDARDS, TERMS, FEES AND ADMINISTRATION	1
§80.1. TEXAS MANUFACTURED HOUSING STANDARDS CODE.....	1
§80.2. DEFINITIONS.	1
§80.3. FEES.....	5
§80.4. ADVISORY COMMITTEE.....	8
SUBCHAPTER B. INSTALLATION STANDARDS AND DEVICE APPROVALS.....	8
§80.20. REQUIREMENTS FOR MANUFACTURER'S DESIGNS AND INSTALLATION INSTRUCTIONS.	8
§80.21. REQUIREMENTS FOR THE INSTALLATION OF MANUFACTURED HOMES.	9
§80.22. GENERIC STANDARDS FOR MOISTURE AND GROUND VAPOR CONTROLS.	13
§80.23. GENERIC STANDARDS FOR FOOTERS AND PIERS.	14
§80.24. GENERIC STANDARDS FOR ANCHORING SYSTEMS.	24
§80.25. GENERIC STANDARDS FOR MULTI-SECTION CONNECTIONS STANDARDS.	35
§80.26. REGISTRATION OF STABILIZING COMPONENTS AND SYSTEMS.	49
SUBCHAPTER C. LICENSEES' RESPONSIBILITIES AND REQUIREMENTS	53
§80.30. ALL LICENSEES' RESPONSIBILITIES.....	53
§80.31. MANUFACTURERS' RESPONSIBILITIES AND REQUIREMENTS.	54
§80.32. RETAILERS' RESPONSIBILITIES AND REQUIREMENTS.	54
§80.33. INSTALLERS' RESPONSIBILITIES AND REQUIREMENTS.	58
§80.34. BROKERS' RESPONSIBILITIES AND REQUIREMENTS.	61
§80.35. SALESPERSON'S RESPONSIBILITIES AND REQUIREMENTS.....	61
§80.36. RETAILERS' REBUILDING RESPONSIBILITIES AND REQUIREMENTS.	61
§80.37. CORRECTION REQUIREMENTS.....	63
§80.38. RIGHT TO ADVANCE COPY OF CERTAIN DOCUMENTS.	64
SUBCHAPTER D. LICENSING	64
§80.40. SECURITY REQUIREMENTS.	64
§80.41. LICENSE REQUIREMENTS.	66
SUBCHAPTER E. ENFORCEMENT	76
§80.70. ENFORCEMENT.	76
§80.71. RULES FOR HEARINGS.	76
§80.72. SANCTIONS AND PENALTIES.	77
§80.73. PROCEDURES FOR HANDLING CONSUMER COMPLAINTS.	79
SUBCHAPTER F. MANUFACTURED HOMEOWNER CONSUMER CLAIMS PROGRAM.....	81
§80.80. ADMINISTRATION OF CLAIMS UNDER THE MANUFACTURED HOMEOWNER CONSUMER CLAIMS PROGRAM.	81
SUBCHAPTER G. STATEMENTS OF OWNERSHIP.....	83
§80.90. ISSUANCE OF STATEMENTS OF OWNERSHIP.	83
§80.91. ISSUANCE OF A TEXAS SEAL.....	87
§80.92. INVENTORY FINANCE LIENS.....	87
§80.93. RECORDING TAX LIENS ON MANUFACTURED HOMES.....	87
§80.94. REPORT TO COUNTY TAX ASSESSOR-COLLECTORS AND COUNTY APPRAISAL DISTRICTS.	88
§80.95. RECORDING OWNERSHIP FOR EMERGENCY HOUSING.	88

SUBCHAPTER A. CODES, STANDARDS, TERMS, FEES AND ADMINISTRATION

§80.1. Texas Manufactured Housing Standards Code. (Effective: December 30, 2007)

The standards and requirements for the installation and construction of manufactured housing adopted by the board in accordance with §1201.251(a)(1) of the Texas Manufactured Housing Standards Act (Standards Act) are as follows:

- (1) The construction standards set out in Chapter VI of the Housing and Community Development Act of 1974, as the same may be amended from time to time, or under any official rule, official interpretation, or adopted standard issued or adopted by the Department of Housing and Urban Development under such law;
- (2) The installation standards set forth in this chapter; and
- (3) Applicable standards for installation components established by
 - (A) Chapter 43 of the latest edition of the International Residential Code;
 - (B) The stabilizing component destruction test failure criteria of the FMHCSS, as implemented by 24 CFR, Part 3280 and the latest edition of the International Residential Code, Appendix E; and
 - (C) The American Wood Preserver's Association and referenced by the latest edition of the International Residential Code Preservation for treated (PT) wood components.
- (4) Collectively, the foregoing, together with the Standards Act and these rules, are referred to as the Texas Manufactured Housing Standards Code ("the Code").

§80.2. Definitions. (Effective: December 8, 2019)

Terms used herein that are defined in the Code and the Standards Act have the meanings ascribed to them therein. The following words and terms, when used in this chapter, shall have the following meanings, unless the context clearly indicates otherwise:

- (1) APA--Administrative Procedure Act, Texas Government Code, Chapter 2001.
- (2) Business days--Includes every day on the calendar except Saturday, Sunday, and federal and state holidays. If there is a time limitation of five

- (5) days or less, within the Standards Act, it is business days unless specified otherwise.
- (3) Chattel Mortgage--Any loan that is not subject to the Real Estate Settlement Procedures Act (RESPA).
 - (4) Coastline--The shoreline that forms the boundary between the land and the Gulf of Mexico or a bay or estuary connecting to the Gulf of Mexico that is more than five miles wide.
 - (5) Cosmetic--Matters of flaws and finish, appearance, materials or workmanship not covered by 24 CFR Part 3280.
 - (6) Credit document--Any executed written agreements between the consumer and creditor that describe or are required in connection with an actual credit transaction.
 - (7) Creditor--A person involved in a credit transaction who:
 - (A) extends or arranges the extension of credit; or
 - (B) is a retailer or broker as defined in the Standards Act and participates in arranging for the extension of credit.
 - (8) Custom designed stabilization system--An anchoring and support system that is not an approved method as prescribed by the state generic standards, manufacturer's installation instructions, or other systems pre-approved by the Department.
 - (9) Dangerous conditions--Any condition which, if present, would constitute an imminent threat to health or safety.
 - (10) DAPIA--The Design Approval Primary Inspection Agency.
 - (11) Department or TDHCA--The Manufactured Housing Division of the Texas Department of Housing and Community Affairs (TDHCA).
 - (12) Deposits--Money or other consideration given by a consumer to a retailer, salesperson, or agent of a retailer to hold a manufactured home in inventory for subsequent purchase or to confirm the agreed price on a home to be specially ordered.
 - (13) Down Payment--An amount, including the value of any property used as a trade-in, paid to a retailer to be applied to the purchase price of a manufactured home, including any goods or services that are a part of that transaction.

- (14) Dwelling unit--One or more habitable rooms which are designed to be occupied for living.
- (15) FMHCSS--Federal Manufactured Home Construction and Safety Standards that implement the National Manufactured Home Construction and Safety Standards Act of 1974, 42 USC 5401, et seq., as amended from time to time.
- (16) Frost Line Zone--An area in Texas designated by the Department, as having a frost line depth to consider when conforming with federal rules.
- (17) Independent testing laboratory--An agency or firm that tests products for conformance to standards and employs at least one engineer or architect licensed in at least one state.
- (18) Inventory Lender--A person that is involved in extending credit for inventory financing secured by manufactured housing.
- (19) IPIA--The Production Inspection Primary Inspection Agency which evaluates the ability of manufactured home manufacturing plants to follow approved quality control procedures and/or provides ongoing surveillance of the manufacturing process.
- (20) Long-Term Lease--For the purpose of determining whether or not the owner of a manufactured home may elect to treat the home as real property, is a lease on land to which the manufactured home has been attached and which:
 - (A) has been approved by each lienholder for the manufactured home by placing on file with the Department written consent to have the home treated as real property; or
 - (B) is for at least five years if the home is not financed.
- (21) Main frame--A chassis or structure serving a similar purpose.
- (22) Manufactured home identification numbers--HUD label number, serial number, or Texas seal number. For the purpose of maintaining ownership and location records, including the perfection of liens, the numbers shall include the HUD label number(s) and the serial number(s) imprinted or stamped on the home in accordance with HUD departmental regulations. For homes manufactured prior to June 15, 1976, the Texas seal number, as issued by the Department, shall be used instead of the HUD label number. If a home manufactured prior to June 15, 1976, does not have a Texas seal, or if a home manufactured after June 15, 1976, does not have a HUD label, a Texas seal shall be purchased

from the Department and attached to the home in upper left corner on the end opposite the tongue end and used for identification in lieu of the HUD label number.

- (23) Manufactured home site--That area of a lot or tract of land on which a manufactured home is or will be installed.
- (24) Permanent foundation--A foundation which meets the requirements of §80.21 of this chapter (relating to Requirements for the Installation of Manufactured Homes) and was constructed according to drawings, as required by that section, which state that the foundation is a permanent foundation for a manufactured home.
- (25) Promptly--Means within the time prescribed by the Standards Act, these Rules, and any administrative order (including any properly granted extension) or, in the case of a matter that constitutes an imminent threat to health or safety, as quickly as reasonably possible.
- (26) Seriousness of Violation – Pursuant to Section 1201.605(c)(1) of the Texas Occupations Code the Department shall assess a higher administrative penalty if the consumer harm or burden is great, as a result of the violation.
- (27) Stabilization systems--A combination of the anchoring and support system. It includes, but is not limited to the following components:
 - (A) Anchoring components--Any component which is attached to the manufactured home and is designed to resist the horizontal and vertical forces imposed on the manufactured home as a result of wind loading. These components include, but are not limited to auger anchors, rock anchors, slab anchors, ground anchors, stabilizing devices, connection bolts, j-hooks, buckles, and split bolts.
 - (B) Anchoring equipment--Straps, cables, turnbuckles, tubes, and chains, including tensioning devices, which are used with ties to secure a manufactured home to anchoring components or other devices.
 - (C) Anchoring systems--Combination of ties, anchoring components, and anchoring equipment that will resist overturning and lateral movement of the manufactured home from wind forces.
 - (D) Diagonal tie--A tie intended to primarily resist horizontal forces, but which may also be used to resist vertical forces.

- (E) Footing--That portion of the support system that transmits loads directly to the soil.
- (F) Ground anchor--Any device at the manufactured home site designed to transfer manufactured home anchoring loads to the ground.
- (G) Longitudinal ties--Designed to prevent lateral movement along the length of the home.
- (H) Shim--A wedge-shaped piece of hardwood or other registered component not to exceed one (1) inch vertical (actual) height.
- (I) Stabilizing components--All components of the anchoring and support system such as piers, footings, ties, anchoring equipment, ground anchors and any other equipment, which supports the manufactured home and secures it to the ground.
- (J) Support system--A combination of footings, piers, caps and shims that support the manufactured home.
- (K) Vertical tie--A tie intended primarily to resist the uplifting and overturning forces.

§80.3. Fees.
(Effective: October 23, 2022)

- (a) License Fees and Renewal Fees:
 - (1) \$850 for each manufacturer's plant license;
 - (2) \$550 for each retailer's sales license;
 - (3) \$350 for each broker's license;
 - (4) \$350 for each installer's license;
 - (5) \$200 for each salesperson's license; and
 - (6) \$25.00 for each reprint of a license.
- (b) Installation Fees:
 - (1) There is a reporting fee of \$75 for the installation of a single section manufactured home and \$25 for each additional section.

- (2) The reporting fee must be submitted to the Department with the completed Notice of Installation (Form T) no later than seven (7) days after which the installation is completed, but not later than three (3) days for installers with a provisional license.
 - (3) Fee distributions to local governmental entities performing inspection functions pursuant to contract with the Department shall be made in accordance with Department procedures and the provisions of the contract.
- (c) Seal Fee: Except for an application by a tax appraiser or a tax assessor-collector, for which there is no fee, there is a fee of \$35 for the issuance of a Texas Seal for one manufactured home section. Any person who sells, exchanges, or offers for sale or exchange one or more sections of used HUD-Code manufactured homes manufactured after June 15, 1976, that do not each have a HUD label affixed, or one or more sections of a used mobile home manufactured prior to June 15, 1976, that do not each have a Texas Seal affixed shall file an Application for Statement of Ownership to the Department for a Texas Seal and issuance of an updated Statement of Ownership. The application shall be accompanied by the seal fee of \$35 per section made payable to the Department.
- (d) Education Fee:
 - (1) Core Education Fee: Each attendee at the regularly offered course of initial instruction in the law and consumer protection regulations for license applicants shall be assessed a fee of \$150. Subject to availability of staff, the Department may provide additional initial instruction courses upon request for a fee of \$150 per attendee plus reimbursement to the Department for the actual costs of the training session and any related costs, such as travel, meal, and lodging.
 - (2) Retailer Education Fee: \$50 for each attendee.
 - (3) Installer Education Fee: \$50 for each attendee.
- (e) There is a fee of \$300 to process an application for a contract to be approved to provide a continuing education program under §1201.113 of the Standards Act.
- (f) Industry Request. The manufacturer, retailer, or installer may request a consumer complaint home inspection. The request must be accompanied by the required fee of \$150.00.
- (g) There is a fee of \$150 for the inspection of a manufactured home which is to be designated for residential use and is elected as personal property after having been designated as real property. The purpose of the inspection is to determine

if the home is habitable. The fee must accompany a written request for inspection and must be submitted either prior to or in connection with the submission of an Application for Statement of Ownership.

- (h) There is a fee of \$200 for the plan review and inspection of a salvaged manufactured home which is to be rebuilt. The purpose of the inspection is to determine if the home is habitable as defined by §1201.453 of the Standards Act so that it may be designated for residential use.
 - (1) The fee and required notification shall be submitted in accordance with §80.36 of this chapter (relating to Retailer's Rebuilding Responsibilities and Requirements).
 - (2) The retailer shall also be charged for mileage and per diem incurred by Department personnel traveling to and from the location of the home.
 - (3) The Department shall invoice the retailer for the charges incurred, and no Statement of Ownership shall be issued until all charges and fees have been paid.
- (i) There is no fee for an initial inspection relating to a complaint. If a re-inspection is requested by a consumer or a licensee, a fee of \$150 will be assessed against any licensee found, by final order, to have violated any warranty or any other requirements of the Standards Act or these rules made the subject of the complaint.
- (j) Fees Relating to Statements of Ownership. Each fee shall accompany the required documents delivered or mailed to the Department at its principal office in Austin.
 - (1) A fee of \$55 will be required for the issuance of a Statement of Ownership.
 - (2) If a correction of a document is required as a result of a mistake by the Department, there is no fee for the issuance of corrected document. However, if the error was not made by the Department, a request for correction of the error must be made on a completed Application for Statement of Ownership and submitted to the Department along with the required fee of \$55 and any necessary supporting documentation.
 - (3) When multiple applications are submitted, the Form M set forth on the Department's website must be completed and attached to the front of the applications to identify each application and reconcile the fee for each application with the total amount of the payment. Failure to provide

this form, properly completed, will delay the application's being deemed complete for processing.

- (4) A priority handling service may be offered by the Department for an additional fee of \$55, for each review of an application, whether the application is complete or incomplete.
- (k) Method of Payment.
 - (1) All checks shall be made payable to the Texas Department of Housing and Community Affairs or TDHCA.
 - (2) All fees for available electronic transactions may also be paid by credit card or ACH, if submitted through Texas Online.
- (l) Loss of Check Writing Privileges. Any person who has more than one (1) time paid for anything requiring a fee under these rules with a check that is returned uncollectible, whether "NSF," closed account, refer to maker, or for any similar reason, is required to make all future payments, if any, by means of money order or cashier's check.
- (m) The director may approve a refund of all or a portion of any fee collected if he or she makes a documented determination showing that:
 - (1) The fee was for a service applied for in error based on incorrect advice from the Department;
 - (2) The fee represented a duplicate payment for a service for which money had already been collected by the Department or a licensee; or
 - (3) A refund is justified and warranted.

§80.4. Advisory Committee.
(Effective: November 6, 2011)

The Board shall designate the membership of an advisory committee of not more than 24 members, that meets the requirements of §1201.251(d) of the Standards Act, and the committee shall report as specified §1201.251(e) of the Standards Act.

SUBCHAPTER B. INSTALLATION STANDARDS AND DEVICE APPROVALS

§80.20. Requirements for Manufacturer's Designs and Installation Instructions.
(Effective: July 21, 2009)

- (a) With each new home, the manufacturer shall provide printed instructions which at a minimum must:

- (1) specify the location, orientation and required capacity of stabilizing components on which the design is based;
 - (2) be filed with the Department;
 - (3) be approved by the manufacturer's DAPIA; and
 - (4) contain DAPIA approval stamps, engineer or architect approval stamps, and the installation manual effective date on each page of the installation instructions or on the cover pages of bound installation manuals, unless an equivalent method of authentication is used for electronically filed documents.
- (b) For used manufactured homes, if a manufacturer determines that one or more of its homes requires a deviation from the generic standards to protect the structural integrity of the home, the manufacturer must include instructions for the necessary deviation in the manufacturer's DAPIA-approved installation instructions and provide a list of all homes affected. The manufacturer must provide a copy to the Department along with a letter informing the Department of the required deviation included in the instructions and giving the Department permission to reproduce and release copies of such instructions upon request. On the Department's website, the Department will maintain a current list of all required deviations from generic standards and will provide a copy to anyone who requests it.
- (c) At least thirty (30) calendar days prior to the effective date of any change, modification, or update to the manufacturer's installation instructions or any appendix, the manufacturer shall file such change, modification, or update with the Department and mail a copy(s) to all the manufacturer's retailers. Links to appendix are posted on the Department's website.
- (d) The manufacturer shall file with the Department additional copies of manufacturer's installation instructions for each model in the number specified by the Department. If no number is specified, one copy of each such set of instructions will suffice.

§80.21. Requirements for the Installation of Manufactured Homes.
(Effective: January 7, 2020)

- (a) All new manufactured homes shall be installed by a licensed installer and in accordance with the home manufacturer's DAPIA-approved installation instructions.
- (b) All used manufactured homes shall be installed by a licensed installer to resist overturning and lateral movement of the home, and the installation must be

completed in accordance with instructions appropriate for the Wind Zone where the home is to be installed as per one of the following:

- (1) the home manufacturer's DAPIA-approved installation instructions;
 - (2) the state's generic standards set forth in §§80.22, 80.23, 80.24, and 80.25 of this subchapter (relating to Installation Standards and Device Approvals);
 - (3) the instructions for a stabilization system registered with the Department in accordance with §80.26 of this subchapter (relating to Registration of Stabilizing Components and Systems); or
 - (4) the instructions for a special stabilization system which:
 - (A) may or may not be a permanent foundation;
 - (B) is for a particular manufactured home or an identified class of manufactured homes to be installed at a particular area with similar soil properties according to county soil survey or other geotechnical reports; and
 - (C) is either:
 - (i) a pre-existing foundation for which a professional engineer or architect licensed in Texas has issued written approval for the installation of a particular home, and the written approval shall be submitted to the Department with the installation report; or
 - (ii) installed in accordance with a custom designed stabilization system drawing that is stamped by a Texas licensed professional engineer or architect. A copy of the stabilization system drawing must be forwarded to the Department along with the installation report.
- (c) When a home is installed on a stabilization system registered with the Department or a special stabilization system, the installer must follow the home manufacturer's DAPIA-approved installation instructions for any aspect of the installation that is not covered by the system's installation instructions or drawings.
- (d) The installer must use stabilizing components that have the required capacity and install them according to the anchor or stabilizing component manufacturer's current installation instructions. All stabilizing components must be resistant to all effects of weathering including that encountered along the Texas gulf coast. Anchors must be made resistant to corrosion. Nonconcrete stabilizing components

and systems for use within 1500 feet of the coastline shall be specifically certified for this use. Preservative treated (PT) wood components shall conform to the applicable standards issued by the American Wood Preserver's Association and referenced by the latest edition of the International Residential Code. The use of re-conditioned equipment (i.e. anchor, strap, and clip) or any anchoring component by licensed installer on the new installations is not permitted. Homeowners are exempt from this requirement provided the integrity of the component is acceptable and approved by the state and the original product number, vendor name, and/or patent number must be legible on the product.

(e) Site Preparation Responsibilities and Requirements:

- (1) The responsible installer of a new manufactured home is responsible for the proper preparation of the site where the manufactured home will be installed.
- (2) A consumer acquiring a used manufactured home to be installed is responsible for the proper preparation of the site where the manufactured home will be installed except as set forth in §80.22 of this chapter (relating to Generic Standards for Moisture and Ground Vapor Controls).
- (3) Whenever a licensed retailer intends to sell a used manufactured home, regardless of where it is located or is to be located, the retailer is required to give the consumer the Site Preparation Notice, for signature by the consumer, in the form set forth on the Department's website PRIOR to the execution of any binding sales agreement.
- (4) Whenever a licensed installer proposes to move a used manufactured home, the installer is required to give the consumer the Site Preparation Notice, for signature by the consumer, in the form set forth on the Department's website PRIOR to entering into a binding agreement to move that home.

- (f) If at the time of installation or within 90 days thereafter as stated on the contract, the retailer or installer provides the materials for skirting or contracts for the installation of skirting, the retailer or installer is responsible for installing any required moisture and ground vapor control measures in accordance with the home installation instructions, specifications of a registered stabilization system, or the generic standards and shall provide for the proper cross ventilation of the crawl space. If the consumer contracts with a person other than the retailer or installer for the skirting, the consumer is responsible for installing the moisture and ground vapor control measures and for providing for the proper cross ventilation of the crawl space.

- (g) Clearance: If the manufactured home is installed according to the state's generic standards, a minimum clearance of 18 inches between the ground and the bottom of the floor joists must be maintained. In addition, the installer shall be responsible for installing the home with sufficient clearance between the I-Beams and the ground so that after the crossover duct prescribed by the manufacturer is properly installed it will not be in contact with the ground. Refer to §80.25 of this chapter (relating to Generic Standards for Multi-Section Connections Standards) for additional requirements for utility connections. The Installer must remove all debris, sod, tree stumps and other organic materials from all areas where footings are to be located.
- (h) Drainage: The Installer is responsible for proper site drainage where a new manufactured home is to be installed. The consumer is responsible for proper site drainage where a used manufactured home is to be installed unless the home is installed in a rental community. Drainage prevents water build-up under the home. Water build-up may cause shifting or settling of the foundation, dampness in the home, damage to siding and bottom board, buckling of walls and floors, delamination of floor decking and problems with the operation of windows and doors.
- (i) Frost Line Zone.
 - (1) The following Texas counties have a 12 inch frost line depth to consider for the installation of a new manufactured home: Armstrong, Bailey, Briscoe, Carson, Castro, Childress, Cochran, Collingsworth, Cottle, Crosby, Dallam, Deaf Smith, Dickens, Donley, Floyd, Foard, Gray, Hale, Hall, Hansford, Hardeman, Hartley, Hemphill, Hockley, Hutchinson, King, Knox, Lamb, Lipscomb, Lubbock, Moore, Motley, Ochiltree, Oldham, Parmer, Potter, Randall, Roberts, Sherman, Swisher, Wheeler, and Wilbarger.
 - (2) For a new home to be installed in a Frost Line Zone county, footings placed in freezing climates must be designed using methods and practices that prevent the effects of frost heave by one of the following methods:
 - (A) Conventional footings. Conventional footings must be placed below the frost line depth for the site unless an insulated foundation or monolithic slab is used (refer to 24 CFR §3285.312(b)(2) and (3)).
 - (B) This is not subject to the provisions in 24 CFR §3285.2(c) that also require review by the manufacturer and approval by its DAPIA for any variations to the manufacturer's installation instructions for support and anchoring.

- (C) Monolithic slab systems. A monolithic slab is permitted above the frost line when all relevant site-specific conditions, including soil characteristics, site preparation, ventilation, and insulative properties of the under floor enclosure, are considered and anchorage requirements are accommodated as set out in 24 CFR §3285.401. The monolithic slab system must be designed by a licensed professional engineer or registered architect:
 - (i) In accordance with acceptable engineering practice to prevent the effects of frost heave; or
 - (ii) In accordance with SEI/ASCE 32-01 as defined in 24 CFR §3285.4.
- (D) Insulated foundations. An insulated foundation is permitted above the frost line, when all relevant site-specific conditions, including soil characteristics, site preparation, ventilation, and insulative properties of the under floor enclosure, are considered, and the foundation is designed by a licensed professional engineer or registered architect:
 - (i) In accordance with acceptable engineering practice to prevent the effects of frost heave; or
 - (ii) In accordance with SEI/ASCE 32-01 as defined in 24 CFR §3285.4.
- (j) Electrical testing. At the time of installation, the following tests must be performed on all new manufactured homes:
 - (1) All site installed or shipped loose fixtures shall be subjected to a polarity test to determine that the connections have been properly made;
 - (2) All grounding and bonding conductors installed or connected during the home installation shall be tested for continuity; and
 - (3) All electrical lights, equipment, ground fault circuit interrupters and appliances shall be subjected to an operational test to demonstrate that all equipment is connected and functioning properly.

**§80.22. Generic Standards for Moisture and Ground Vapor Controls.
(Effective: July 21, 2009)**

- (a) If the used manufactured home is installed according to the state's generic standards and the space under the home is to be enclosed with skirting and/or

other materials provided by the retailer and/or installer, the enclosure must meet the following requirements:

- (1) At least one access opening that does not require the use of tools to gain access shall not be less than 18 inches in any dimension and not less than three square feet in area shall be provided by the installer. The access opening shall be located so as to enable, to the extent reasonably possible, the visual inspection of water supply and sewer drain connections.
 - (2) If a clothes dryer exhaust duct, air conditioning condensation drain, or combustion air inlet is present, the installer must pass it through the skirting to the outside. All air conditioning condensation lines must be installed in such manner that prevents ponding within 5 feet of the foundation.
 - (3) Crawl space ventilation must be provided at the rate of minimum 1 square foot of net free area, for every 150 square feet of floor area.
 - (4) At least six openings shall be provided, one at each end of the home and two on each side of the home. There must be a ventilation within 3 feet of each corner. The openings shall be screened or otherwise covered to prevent entrance of rodents (note: screening will reduce net free area). For example, a 16'x76' single section home has 1216 square feet of floor area. This 1216 square feet divided by 150 equals 8.1 square feet or 1166 square inches of net free area crawl space ventilation.
- (b) The generic ground vapor control measure shall consist of a ground vapor retarder that is minimum 6 mil polyethylene sheeting or its equivalent, installed so that the area under the home is covered with sheeting and overlapped approximately 12 inches at all joints. Any tear larger than 18 inches long or wide must be taped using a material appropriate for the sheeting used. The laps should be weighted down to prevent movement. Any small tears and/or voids around construction (footings, anchor heads, etc.) are acceptable.

§80.23. Generic Standards for Footers and Piers.
(Effective: January 20, 2009)

- (a) Proper sizing of footings depends on the load carrying capacity of both the piers and the soil. To determine the load bearing capacity of the soil, the installer may use any of the following methods:
 - (1) Using a pocket penetrometer;
 - (2) Soil surveys from the U.S. Department of Agriculture;

- (3) Values from tables of allowable or presumptive bearing capacities given in local building codes. Such tables are commonly available from the local authority having jurisdiction; or
- (4) Any other test data from soil analysis reports.

FOOTER CAPACITIES (LBS)

-----Soil Bearing Capacity-----

Footer size	1000psf	1500psf	2000psf	2500psf	3000psf or greater
16x16x4	1700	2700	3500	4400	5300
20x20x4	2700	4100	5500	6900	8300
16x32x4	3500	5200	6800	8600	10400
24x24x4	4000	6000	8000	10000	12000

Notes:

- 1) 8x16x4 footers may be used for perimeter and/or exterior door supports. Capacity is half that of the tabulated values for a 16x16x4 footer. For double 8x16x4 footers use the 16x16x4 row.
- 2) Footers of material other than concrete may be used if registered with the Department and the listed capacity and area is equal to or greater than the footer it replaces. Concrete footers of sizes not listed may be used as long as their size is equal to or greater than the size listed.
- 3) Footers with loads greater than 8,000 lbs. require a double stacked pier.
- 4) All poured concrete is minimum 2500 psi at 28 days.
- 5) Actual footer dimensions may be 3/8 inch less than the nominal dimensions for solid concrete footers conforming to the specifications in ASTM C90-99a, Standard Specification for Load bearing Concrete Masonry Units.

SOIL TYPE CHART

Class of Material	Load-Bearing Pressure (lbs per s.f.)
Crystalline bedrock	12,000
Sedimentary and foliated rock	4,000
Sandy gravel and/or gravel (GW and GP)	3,000
Sand, silty sand, clayey sand, silty gravel and clayey gravel (SW, SP, SM, SC, GM and GC)	2,000
Clay, sandy clay, silty clay, clayey silt, silt and sandy silt (CL, ML, MH and CH)	1,500 ^b

For information only. Exact soil type must be determined by a certified lab.

- (b) The footing must be placed on firm, undisturbed soil, or fill compacted to at least 90% of its maximum relative density is required and must be verified every 6”–8” vertically on the build-up. Installation on loose, noncompacted fill may result in settlement/movement of the home and may invalidate the home's limited warranty.
- (c) Footer Configurations.

Notes: Typical pier pad: 16 in. x 16 in. x 4 in. thick precast concrete.

FOOTER CONFIGURATIONS

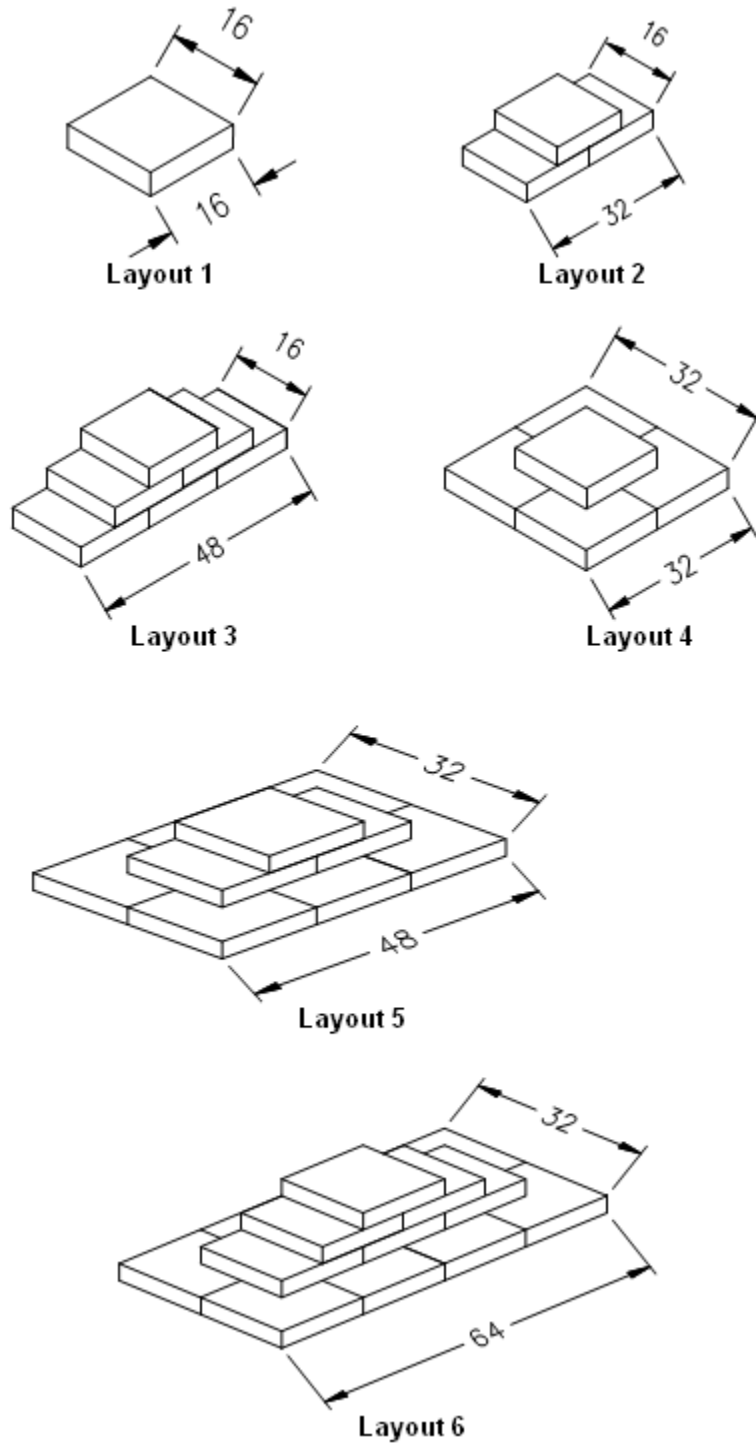

DOUBLE 8x16x4

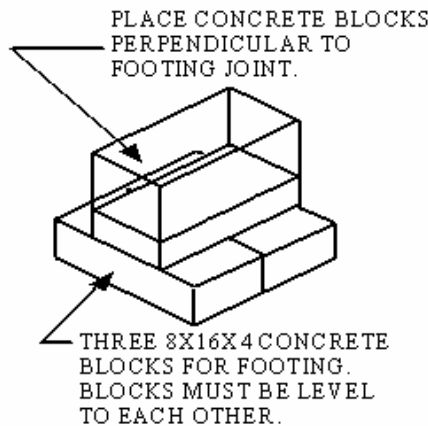

Layout 7

- (d) Footer sizing and capacities: The Footer Capacities table in subsection (a)(4) of this section represent maximum loads and spacings based on footer size and soil bearing capacity. Other footers may be used if equal or greater in bearing area than those footer sizes tabulated.
- (e) Piers and pier spacings: Spacing and location of piers shall be in accordance with the tables listed in this chapter.
- (1) Spacing shall be as even as practicable avoiding obstacles that are not in control of the installer along each main I-Beam. Pier spacing may exceed tabulated values up to 30% so long as the total pier count remains the same. End piers are to be located within 24 inches of the end of the main frame.
 - (2) Piers shall extend at least 6 inches from the centerline of the I-Beam or be designed to prevent dislodgment due to horizontal movement of less than 4 inches.
 - (3) Load bearing supports or devices shall be registered with the Department in accordance with §80.26 of this chapter (relating to Registration of Stabilizing Components and Systems).
 - (4) Sidewall openings greater than 4 feet shall have perimeter piers located under each side of the opening, *i.e.* patio doors, recessed porches/entries, bay windows and porch posts. Perimeter piers for openings are not required for endwalls.
- (f) Pier design: Piers shall be constructed per the details in the Pier Design.

PIER DESIGN (SINGLE & MULTI-SECTION STACK)

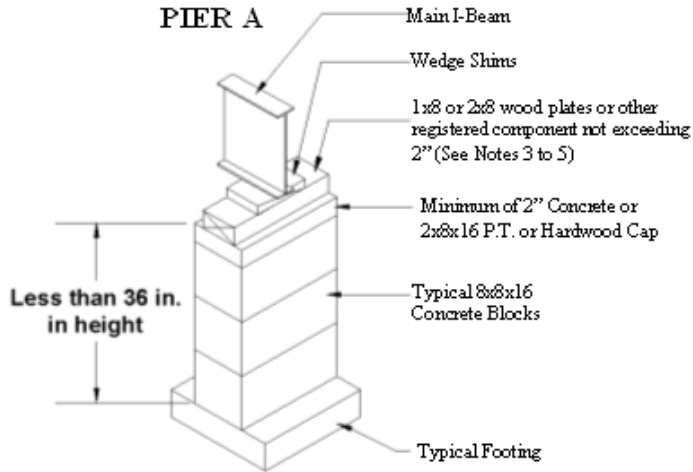

Pier A: Single stack of solid or open cell, 8x8x16 concrete blocks. Maximum height is 36 inches as measured from the top of the footer to the top of the last concrete block. Concrete blocks are installed with their lengths perpendicular to the main I-Beam. Open cells must be vertical and in alignment.

Pier B

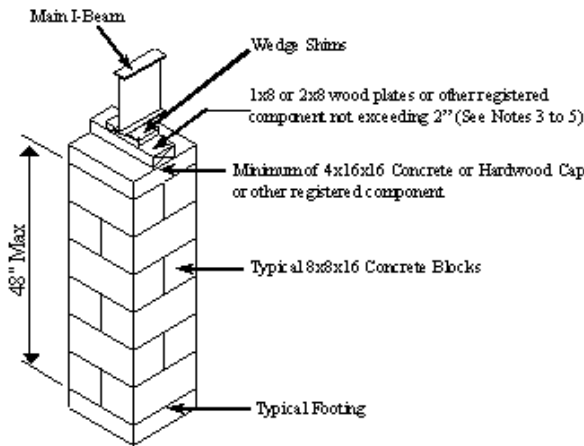

Pier B: Interlocked double stack of solid or open cell 8x8x16 concrete blocks. The maximum height is 48 inches as measured from the top of the footer to the top of the last concrete block. Piers of greater heights are allowed if they are within limits established in adopted federal standards. The pier is capped with a minimum 16x16x4 concrete cap. Open cells must be vertical and in alignment. Each course of open cell blocks must be perpendicular to the previous course.

Pier B-1

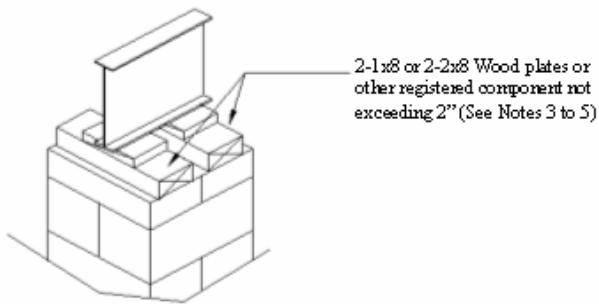

Note:

- 1) Open cell and solid concrete blocks shall meet ASTM-C90-99a, Standard Specification for load bearing Concrete Masonry Units.

- 2) Support system components are to be undamaged and installed in a manner to accomplish the purpose intended.
- 3) Either wood caps or shims must be used between I-Beam and concrete.
- 4) Preservative treated (PT) wood components shall conform to the applicable standards issued by the American Wood Preserver's Association and referenced by the latest edition of the International Residential Code.
- 5) When concrete caps are used, wood plates or other registered components are required. When wood caps are used, wood plates shall not be used. A maximum of 4 inches of wood including shims, nominal is allowed.

(1) Shimming (if needed): Shims are commonly used as a means for leveling the home and filling any voids left between the bottom flange of the I-Beam and the top of the pier cap. Wedge shaped shims must be installed from both sides of the I-Beam to provide a level bearing surface. The allowable height must not exceed 1 inch. Shims shall be a minimum of 3"x 6" nominal. All adjustment shims (marriage and perimeter) must be installed in manner which prevents dislodgement.

(2) Table for pier spacing without perimeter piers.

PIER LOADS (LBS) AT TABULATED SPACINGS
(WITHOUT PERIMETER SUPPORTS)

----- maximum pier spacing -----

Unit Width(ft)	4 ft o.c.	5 ft o.c.	6 ft o.c.	7 ft o.c.	8 ft o.c.
12 Wide	1725	2150	2600	3000	3400
14 wide	2000	2500	3000	3500	4000
16 Wide	2350	2900	3500	4100	4700

Note: 18 ft. wides require perimeter support.

Example:

Step 1: Determine maximum pier spacing for a 16 ft. wide x 76 ft. long single section with a soil bearing capacity of 1500 psf. Footer size to be used is a single 16x16x4 precast concrete footer.

Step 2: Look up the maximum load for a single 16x16x4 pad set on 1500 psf soil. Answer = 2700 psf

Answer: In the table in the column for 16 ft. wide, find the on-center spacing (o.c.) load equal to or less than the footer capacity of 2700 lbs. The 4ft column shows minimum capacity of 2350 lbs. Therefore, for a 16 ft. wide and a soil bearing capacity of 1500 psf using 16x16x4 footers the maximum pier spacing is 4 ft. o.c.

- (3) Table for pier spacing WITH perimeter supports and the Perimeter Pier Front and Side View.

PIER LOADS (LBS) AT TABULATED SPACINGS
(WITH PERIMETER SUPPORTS)

----- maximum I-Beam pier spacing -----

Unit width (ft)	4 ft o.c.	6 ft o.c.	8 ft o.c.	10 ft o.c.	12 ft o.c.
12 Wide	750	1150	1500	1900	2300
14 Wide	1050	1600	2100	2600	3100
16 Wide	1200	1800	2400	3000	3600
18 Wide	1450	2150	2850	3600	4300

Note: Maximum I-Beam pier spacing is 8 ft. o.c. for 8" I-Beam, 10 ft. o.c. for 10" I-Beam and 12 ft. o.c. for 12" I-Beam or the resultant maximum spacing based on soil bearing and footer size per the table in §80.23(a)(4), whichever is less.

----- maximum perimeter pier spacing -----

Unit width (ft)	4 ft o.c.	5 ft o.c.	6 ft o.c.	7 ft o.c.	8 ft o.c.
12 Wide	1000	1200	1500	1700	1900
14 Wide	1100	1400	1650	1900	2200
16 Wide	1300	1600	1900	2250	2500
18 Wide	1600	2000	2300	2700	3000

Example: Determine maximum I-Beam pier spacing for a 16 ft. wide with 12" I-Beam, perimeter support and 1500 psf soil bearing capacity.

Step 1 From the table in §80.23(a)(4), the maximum load for a 16x16x4 at 1500 psf soil is 2700 lbs.

Step 2: From the I-beam pier spacing table, the I-Beam pier load @ 10 ft. o.c. is 3000 lbs ==> no good, the I-Beam pier load @ 8 ft. o.c. is 2400 lbs ==> ok
I-Beam pier spacing is at 8 ft. o.c.

Step 3: The perimeter pier load @ 8ft. o.c. is 2500 lbs =====> ok
Perimeter pier spacing is at 8 ft. o.c.

PERIMETER PIER FRONT & SIDE VIEW

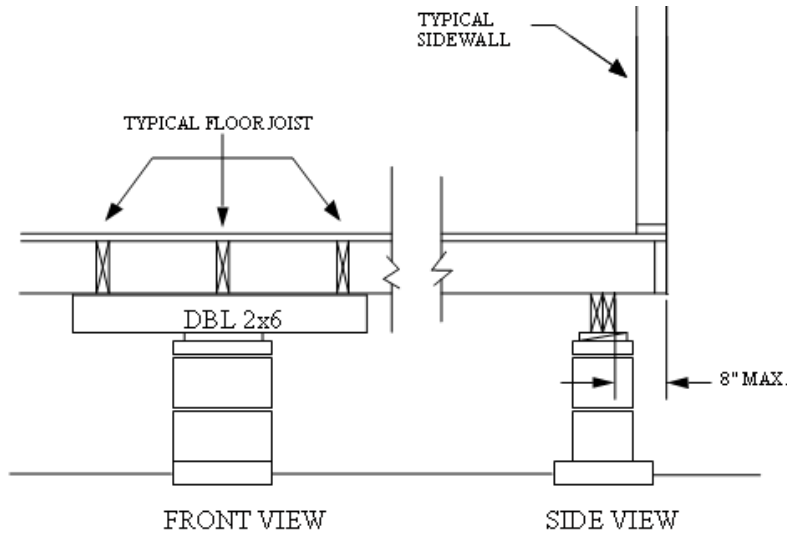

Notes:

- 1) Perimeter pier may be inset from edge of floor up to 8". The 2x6 brace may be omitted if the front face of a perimeter pier is flush with the perimeter joist and the perimeter pier supports the intersection of an interior joist and perimeter joist.
- 2) Dbl 2x6 are min. #3 Yellow Pine or pressure treated Spruce-Pine, nailed together with min. 16d galvanized nails 2-rows at maximum 8" o.c.
- 3) 2x6 brace must span at least two (2) but not more than three (3) floor joists.

(g) Typical Multi-Section Pier Layout.

TYPICAL MULTI-SECTION PIER LAYOUT

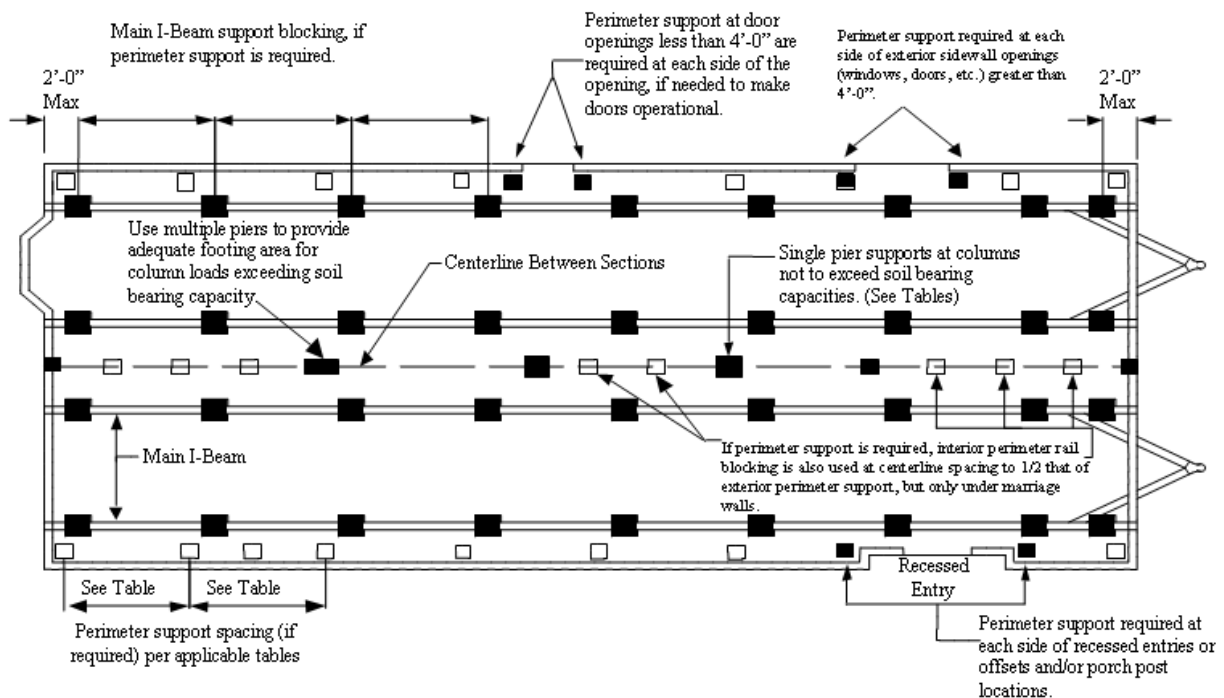

(h) Typical Single Section Pier Layout.

TYPICAL SINGLE SECTION PIER LAYOUT

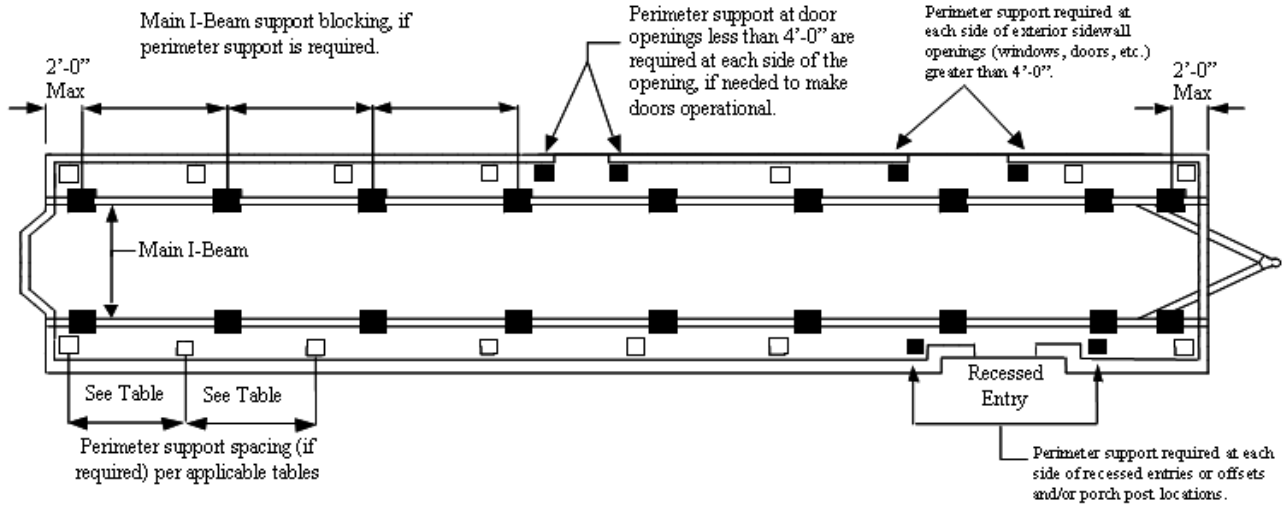

(i) Multi-section units mating line column supports:

- (1) On multi-section units, openings larger than 4 feet must have piers installed at each end of the opening. And within 6 inches of each end.

DETERMINING COLUMN LOAD

To determine the column load for Column #1 at the endwall look up Span "A" in the table in §80.23(i)(4). To determine the column load for Column #2, look up the combined distance of both Span "A" and Span "B". To determine the column load for Column #3 look up Span "B" in the table. (NOTE: Mating line walls not supporting the beam must be included in the span distance.) To determine the loads for Columns #4 and #5 look up Span "C". For Columns #6 and #7 look up span "D".

MARRIAGE LINE ELEVATION

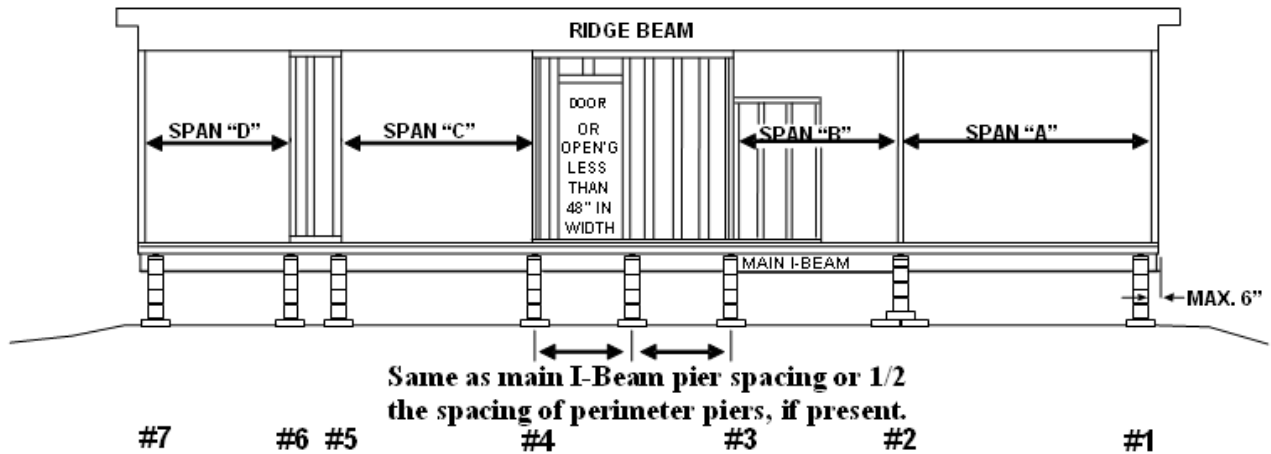

- (2) Column loads for each section may be combined when the columns are opposite each other. The footer must be sized for the combined loading.
- (3) Additional piers are required under marriage walls (see wall between column #3 and #4 in the Marriage Line Elevation figure in paragraph (1) of this subsection. The maximum spacing is the same as the spacing at the main I-Beams, without perimeter piers, and one half the spacing of the perimeter piers, with perimeter piers installed.
- (4) See the table for the mating line column loads.

Mating Line Column Loads

-----Unit width in feet (nominal)-----

Span in feet	12 Wide	14 Wide	16 Wide
4	720	840	960
6	1080	1260	1440
8	1440	1680	1920
10	1800	2100	2400
12	2160	2520	2880
14	2520	2940	3360
16	2880	3360	3840
18	3240	3780	4320
20	3600	4200	4800
22	3960	4620	5280
24	4320	5040	5760
26	4680	5460	6240
28	5040	5880	6720
30	5400	6300	7200
32	5760	6720	7680
34	6120	7140	8160
36	6480	7560	8640

Note: If actual span is not shown use next higher tabulated span.

- (j) Temporary support is required to insure the structural continuity of homes placed at the retail location. Thirty (30) days after the arrival of multi-section and sixty (60) days after the arrival of single-section manufactured dwellings to the retail location, homes must be temporarily lot set. If the manufacturer has instructions for temporary blocking, home should be blocked according to the manufacturer specifications. In absence of any manufacturer instructions, State Generic requirement, either paragraph (1) or (2) of this subsection, shall be used:
 - (1) Manufacturer dwellings supported by its running gear (left on their wheels and draw bar/hitch) shall be adequately supported under the

main beam (I-beam) of within 5 feet of each end of the beam, within 5 feet of a supporting wheel and 10 feet on-center of each floor section. Any required marriage line and perimeter pier locations that are clearly marked by the manufacturer are also to be installed. Sidewall openings less than 4 feet in length do not have to be supported. Multi-section homes shall be sealed at the centerline and at all other openings to prevent exposure to the elements.

- (2) Manufactured dwellings not supported on their running gear shall be adequately supported under each main frame (I-beam) within 5 feet of each end of the home and 10 feet on-center along the length of the main beam. Any required marriage line and perimeter pier locations that are clearly marked by the manufacturer are also to be installed. Sidewall openings less than 4 feet in length do not have to be supported. Multi-section homes shall be sealed at the centerline and at all other openings to prevent exposure to the elements.

§80.24. Generic Standards for Anchoring Systems.
(Effective: January 29, 2008)

- (a) General Requirements: For units built on or after September 1, 1997, the installer must verify that the unit is designed for the Wind Zone in which it is to be installed and must follow all applicable installation instructions for that Wind Zone as set forth herein. Note: A Wind Zone I unit, built on or after September 1, 1997, may not be installed in a Wind Zone II area. However, a Wind Zone II unit may be installed in a Wind Zone I area. The counties are defined in the FMHCSS.
- (b) Material Specifications:
 - (1) Strapping shall be Type 1, Finish B, Grade 1 steel strapping, 1.25 inches wide and 0.035 inches in thickness, certified by a licensed professional engineer or architect as conforming with the American Society for Testing and Materials (ASTM) Standard Specification D3953 91, Standard Specification for Strapping, Flat Steel, and Seals. Strapping shall be marked at least every five feet with the marking described by the certifying engineer or architect.
 - (2) Tie materials shall be capable of resisting an allowable working load of 3,150 pounds with no more than 2% elongation and shall withstand a 50% overload (4,725 pounds total). Ties shall have a resistance to weather deterioration at least equivalent to that provided by coating of zinc on steel of not less than 0.30 ounces per square foot on each side of the surface coated (0.0005 inches thick), as determined by ASTM Standards Methods of Test for Weight of Coating on Zinc-coated

(galvanized) Iron or Steel Articles (ASTM A 90-81). Slit or cut edges of zinc-coated steel strapping are not required to be zinc coated. Ties shall be designed and installed to prevent self disconnection when the ties are slack.

- (3) Anchor spacing ONLY applies to units with roof pitch of 20 degrees or less. For anything over 20 degrees, it must be designed by a professional engineer or architect.

(c) Anchors shall be installed:

- (1) in direction of load.

ANCHOR INSTALLATION

Notes:

- 1) Anchor head must be flush or not to exceed more than 1 inch from the ground at insertion point.
- 2) Anchor head may be inset a maximum of 6 inches from the vertical outer edge of the floor framing to allow for skirting installation.

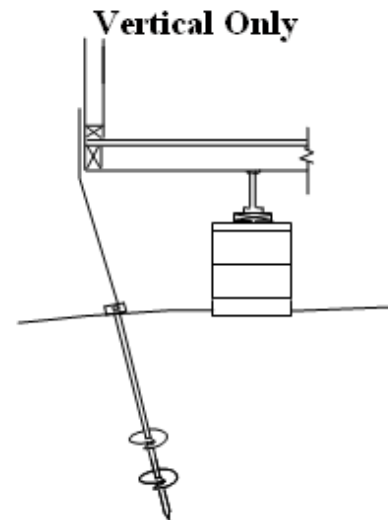
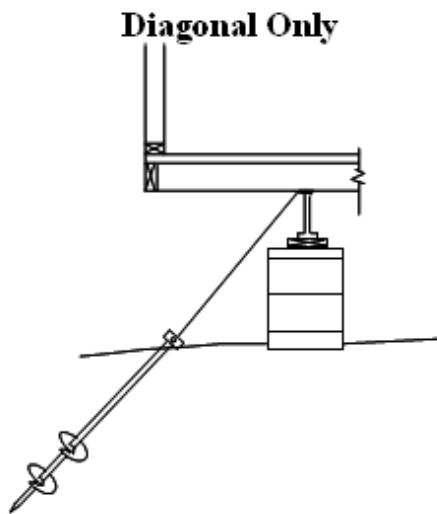

- (2) against direction of load (vertical and/or angled), and a stabilizer plate must be installed. See the following Placement of Stabilizing Devices.

PLACEMENT OF STABILIZING DEVICES

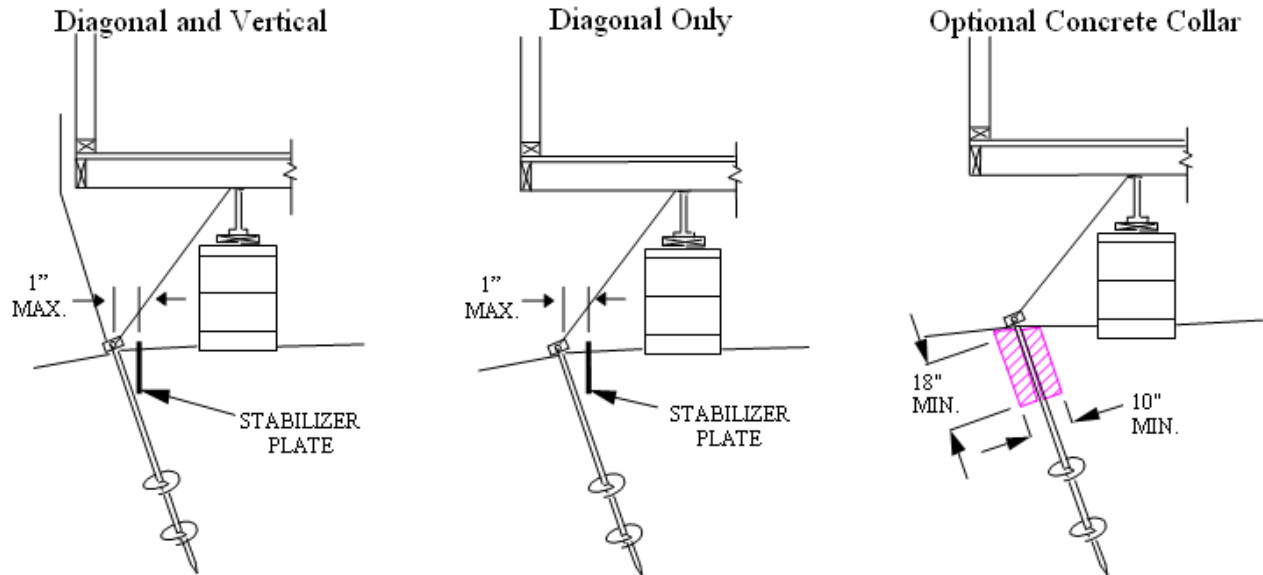

Notes:

- 1) Stabilizer plate may be replaced with a concrete collar that is at least 18 inches deep and 10 inches in diameter or other approved devices.
- 2) Diagonal tie must depart from the top of the I-Beam as shown.
- 3) The top of the stabilizer plate must be within 1 inch of the anchor shaft.
- 4) Stabilizer plates and other approved devices must be installed in accordance with the product manufacturer's instructions.

(d) WIND ZONE I Installation:

(1) Typical anchor layout, single and multi-section units (WIND ZONE I ONLY).

WIND ZONE I – SINGLE/MULTI-SECTION INSTALLATION

(Refer to other figures for depictions of proper anchor and stabilizer device installation.)

Figure 1: Single Section

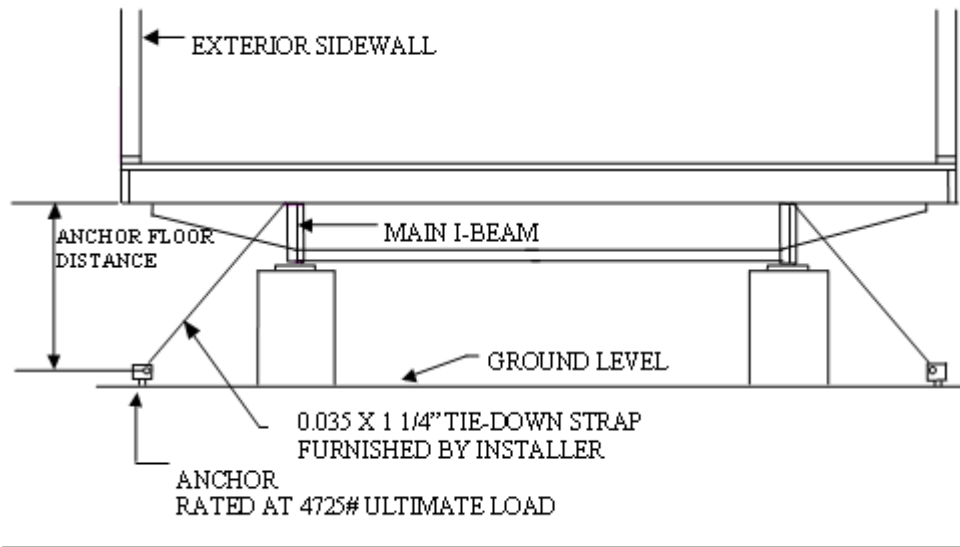

Notes:

- 1) Single section units require diagonal ties to be directly opposite each other.
- 2) All existing vertical ties must be connected to a ground anchor.
- 3) Diagonal tie spacing per the table. Vertical distance in this table refers to the distance of the anchor head to the underside of the floor joists as shown above.
- 4) Diagonal tie must depart from the top of the I-Beam as shown.

Figure 2: Multi-Section

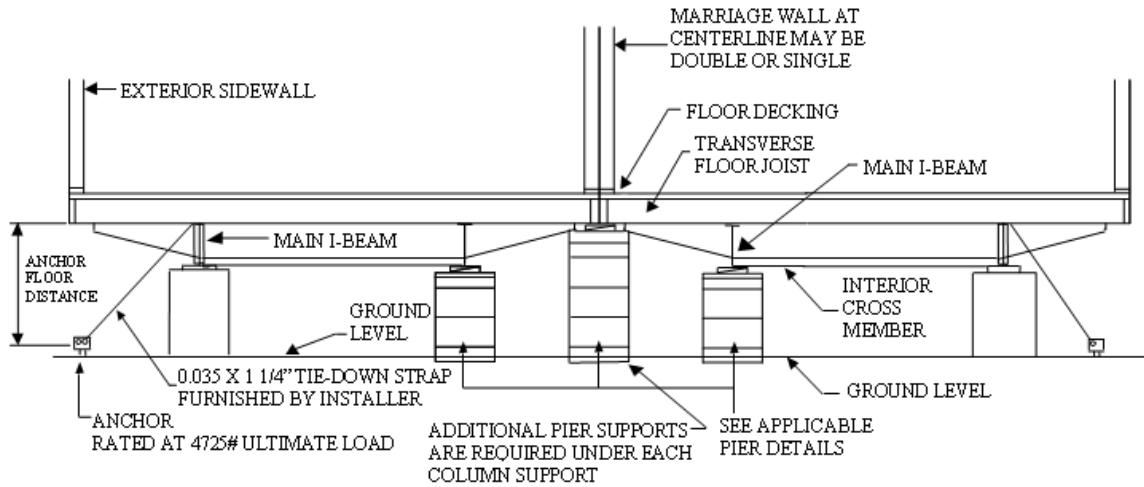

Notes:

- 1) Multi-section units require diagonal ties on the outer main I-Beams only.
- 2) Diagonal ties need not be directly opposite each other.
- 3) Diagonal tie spacing per the table. Vertical distance in this table refers to the distance of the anchor head to the underside of the floor joists as shown above.
- 4) Existing vertical ties must be connected to a ground anchor.
- 5) Diagonal tie must depart from the top of the I-Beam as shown.

(2) Maximum spacing for Diagonal Ties for Wind Zone I.

MAXIMUM SPACING FOR DIAGONAL TIES

Minimum Nominal Widths Single/Double Section

Max. Vertical Distance	12/24 wide	14/28 wide	16/32 wide	18/36 wide
20" to 24"	11 ft	14 ft	15 ft	16 ft
25" to 29"	9 ft	12 ft	14 ft	15 ft
30" to 40"	8 ft	10 ft	12 ft	14 ft
41" to 48"	7 ft	9 ft	11 ft	13 ft
49" to 60" (see note 3)	6 ft	8 ft	10 ft	12 ft
61" to 67" (see note 3)	5 ft	6 ft	8 ft	10 ft
Minimum number of longitudinal ties, each end of each section.	1 at min. 58° angle from vertical	2 at min. 32° angle from vertical	2 at min. 38° angle from vertical	2 at min. 46° angle from vertical

Notes:

- 1) This chart applies to single and multi section homes.
- 2) Anchoring components are rated at 4725 lbs. ultimate load. Anchoring components and equipment shall be installed in accordance with the anchoring component and equipment manufacturer's installation instructions.
- 3) Single section units shall have diagonal ties directly opposite each other along the two main I-beams. Multi section units need diagonal ties on the outer-most main I-beam only. When vertical distance exceeds 48", connect diagonal tie to opposite beam.
- 4) Ties installed at each end of the home shall be within 24 inches of each end of the applicable I-beam.
- 5) The distance between any two ties may be exceeded to avoid an obstruction, as long as the total number of ties remains the same, and no two anchors shall be within 4 ft of each other.
- 6) Any vertical ties present on homes must be attached to a ground anchor. Both vertical and diagonal ties may be connected to a single double-headed anchor, if the anchor manufacturer's installation instructions allow for the combined loading.
- 7) The vertical distance is measured from the anchor head to the underside of the floor joists.
- 8) No two anchors shall be within 4 ft of each other.
- 9) Other stabilizing systems registered with the Department may replace longitudinal and/or lateral ties as long as the system manufacturer's installation instructions are followed.

(3) Minimum Number of Diagonal Ties for Wind Zone I. Table based on 2 feet inset of anchors at each end.

**MINIMUM NUMBER OF DIAGONAL TIES
REQUIRED PER SIDE, PER UNIT LENGTH**

unit length (ft)	----- o.c. spacing (ft) -----												
	4	5	6	7	8	9	10	11	12	13	14	15	16
40	10	8	7	6	6	5	5	4	4	4	4	3	3
42	11	9	7	6	6	5	5	5	4	4	4	4	3
44	11	9	8	7	6	5	5	5	4	4	4	4	4
46	12	9	8	7	6	5	5	5	5	4	4	4	4
48	12	10	8	7	7	6	5	5	5	4	4	4	4
50	13	10	9	8	7	6	6	5	5	5	4	4	4
52	13	11	9	8	7	6	6	5	5	5	4	4	4
54	14	11	9	8	7	7	6	6	5	5	5	4	4
56	14	11	10	8	8	7	6	6	5	5	5	4	4
58	15	12	10	9	8	7	6	6	6	5	5	5	4
60	15	12	10	9	8	7	7	6	6	5	5	5	5
62	16	13	11	9	8	7	7	6	6	5	5	5	5
64	16	13	11	10	9	8	7	6	6	6	5	5	5

unit length (ft)	4	5	6	7	8	9	10	11	12	13	14	15	16
66	17	13	11	10	9	8	7	7	6	6	5	5	5
68	17	14	12	10	9	8	7	7	6	6	6	5	5
70	18	14	12	10	9	8	8	7	7	6	6	5	5
72	18	15	12	11	10	9	8	7	7	6	6	6	5
74	19	15	13	11	10	9	8	7	7	6	6	6	5
76	19	15	13	11	10	9	8	8	7	7	6	6	6

Note: If unit length is not listed use next higher tabulated length.

- (4) When auger anchors cannot be inserted into a difficult soil after moistening, such as mixed soil and rock or caliche (heavily weathered limestone) that is not solid rock, cross drive rock anchors may be used in accordance with the values and notes for the table modified as follows:
- (A) Since the ultimate anchor pull out in the difficult soil will be reduced, the maximum spacing for diagonal ties per side is one half the spacing allowed by the table in paragraph (2) of this subsection which will require adding one additional cross drive rock anchor for each anchor specified for the sides and ends;
 - (B) The rods of the cross drive rock anchors must be fully inserted, have at least 24 inches of the rod lengths embedded in the difficult soil, and be restrained from horizontal movement by a stabilizer device between the rods and the home; and
 - (C) Each cross drive rock anchor is connected to one diagonal tie and is not connected to a vertical tie.
- (5) Where vertical tie locations are not easily discernable, the vertical ties may be connected to the main I-Beam rails and the anchor installed directly below that connection point. The diagonal tie must be connected to the opposite main I-Beam. In no case shall the distance between those ties exceed 5'-4" on-center.

(e) WIND ZONE II Installation:

- (1) In place of the requirements as shown in subsection (d) of this section, units designed for Wind Zone I and built prior to September 1, 1997, and units designed for Wind Zone II and built prior to July 13, 1994, require diagonal ties as set forth in this paragraph when these units are installed in Wind Zone II. See also §1201.256 of the Standards Act. Items not specifically addressed in this section are the same as for Wind Zone I installations.

MAXIMUM SPACING FOR DIAGONAL TIES (WIND ZONE II)
PER SIDE OF THE ASSEMBLED UNIT

Minimum Nominal Widths Single/Double Section				
Max. Vertical Distance	12/24 wide	14/28 wide	16/32 wide	18/36 wide
20" to 24"	7 ft	8 ft	8 ft	8 ft
25" to 29"	6 ft	7 ft	8 ft	8 ft
30" to 40"	5 ft	6 ft	7 ft	8 ft
41" to 48"	4 ft	5 ft	6 ft	7 ft
49" to 60" (see note 2)	4 ft	6 ft	6 ft	6 ft
Minimum number of longitudinal ties, each end of each section.	2 at min. 58° angle from vertical	2 at min. 32° angle from vertical	3 at min. 38° angle from vertical	3 at min. 46° angle from vertical

Notes:

- 1) *This chart applies to single and multi section homes.*
- 2) *Single section units shall have diagonal ties directly opposite each other along the two main I-beams. Multi section units need diagonal ties on the outer-most main I-beam only. When vertical distance exceeds 48", connect diagonal tie to opposite beam.*
- 3) *Ties installed at each end of the home shall be within 24 inches of each end of the applicable I-beam.*
- 4) *The distance between any two ties may be exceeded to avoid an obstruction, as long as the total number of ties remains the same, and no two anchors shall be within 4 ft of each other.*
- 5) *Any vertical ties present on homes must be attached to a ground anchor. Both vertical and diagonal ties may be connected to a single double-headed anchor, if the anchor manufacturer's installation instructions allow for the combined loading.*
- 6) *The vertical distance is measured from the anchor head to the underside of the floor joists.*
- 7) *No two anchors shall be within 4 ft of each other.*
- 8) *Other stabilizing systems registered with the Department may replace longitudinal and/or lateral ties as long as the system manufacturer's installation instructions are followed.*

- (2) Units built to Wind Zone II on or after July 13, 1994.
 - (A) Units built to Wind Zone II on or after July 13, 1994, should have either built-in, or provisions for connecting, vertical ties along the sidewall(s) of each unit(s). A diagonal tie must be installed at each vertical tie location (except for designated shearwall tie). Built-in vertical ties shall be connected to anchors. If there are brackets or other provisions for connecting vertical ties, vertical ties shall be added at the brackets or provisions and connected to anchors.
 - (B) Only factory installed vertical ties may be closer than 4 feet from each other.
 - (C) Where tie locations are clearly marked as a shear wall strap, a perimeter pier must be installed at that location. Diagonal tie is not required.
 - (D) Where the vertical tie spacing exceeds 8'-0" on-center (see also note 6 in the table in this paragraph for exception), the anchoring system must be approved by the home manufacturer's installation manual, or designed by a professional engineer or architect licensed in the state of Texas.
 - (E) Where pier heights exceed 36 inches in height, the diagonal strap shall be connected to the opposite I-Beam.
- (3) Multi-section centerline anchoring requirements (Wind Zone II only):
 - (A) Centerline anchor ties are required for ALL Wind Zone II installations, regardless of the date the unit was manufactured, when installation occurs on or after the effective date of these rules.
 - (B) Factory installed centerline vertical ties, brackets, buckles or any other connecting devices must be connected to a ground anchor. No additional anchors as described in subparagraph (D) of this paragraph are required.
 - (C) To avoid obstructions and/or piers and footers, the anchor may be offset up to 12 inches perpendicular to the centerline.
 - (D) Where factory preparations do not exist, install anchors and angle iron brackets at each side of mating line openings wider than 48 inches.

- (i) Where equal spans exist opposite each other (*i.e.*, each section), a double bracket assembly may be used. The maximum opening is per the table in subsection (f)(4) of this section. Total uplift load may not exceed the anchor and/or strap capacity (*i.e.*, 3150 pounds).
 - (ii) The angle iron bracket is minimum 1 ½" x 1 ½" x 11 gauge. The holes for the lag screws are a maximum of 4 inches apart and ¾" from the edge of the bracket.
 - (iii) Lag screws/bolts are minimum 3/8" diameter x 3 inches, full thread. Note: Pre drill pilot holes.
- (4) For openings separated by a wall or post 16 inches or less in width, the opening span is the total of the spans on each side of the wall/post.
- (f) Bracket Installation.
- (1) See the table in paragraph (4) of this subsection concerning the maximum centerline wall opening for column uplift brackets.
 - (2) Use a single bracket for openings which exist on one section only. Use double bracket where openings are opposite each other on two sections of the home.
 - (3) When only one bracket assembly is required, it may be installed on either side of the column/opening stud(s), but no more than 12 inches from the column or opening stud(s).
 - (4) When two bracket assemblies are required, they must be installed on each side of the column/opening stud(s), but no more than 12 inches from the column/opening stud(s), and they must be angled away from each other a minimum of 12 inches.

MAXIMUM CENTERLINE WALL OPENING FOR COLUMN UPLIFT BRACKETS

----- Maximum opening based on floor widths -----

	12 Wide (140" max)	14 Wide (164" max.)	16 Wide (186" max.)	18 Wide (210" max.)
One Single Bracket (2-lags) either side of column.	17'-6"	15'-0"	13'-3"	11'-9"
Two Single Brackets (2-lags each), one each side of column.	35'-0"	30'-0"	26'-6"	23'-6"
One Double Bracket (4-lags) <i>either</i> side of column. Spans are on both sections, opposite each other.	31'-9"	27'-2"	23'-11"	21'-2"
*Two Double Brackets (4-lags) either side of column. Spans are on both sections, opposite each other.	40'-0"	40'-0"	40'-0"	40'-0"

*** For openings larger than 40'-0", consult a local licensed professional engineer or architect.**

- (5) Example: A double section unit with each section being 14 feet wide;
- (A) Span "A" is 18'-0", matching span both sections;
 - (B) Span "B" is 14'-8", matching span both sections;
 - (C) Span "C" is 6'-8", matching span both sections; and
 - (D) Span "D" is 13'-4", one side only.

ANCHOR SPAN

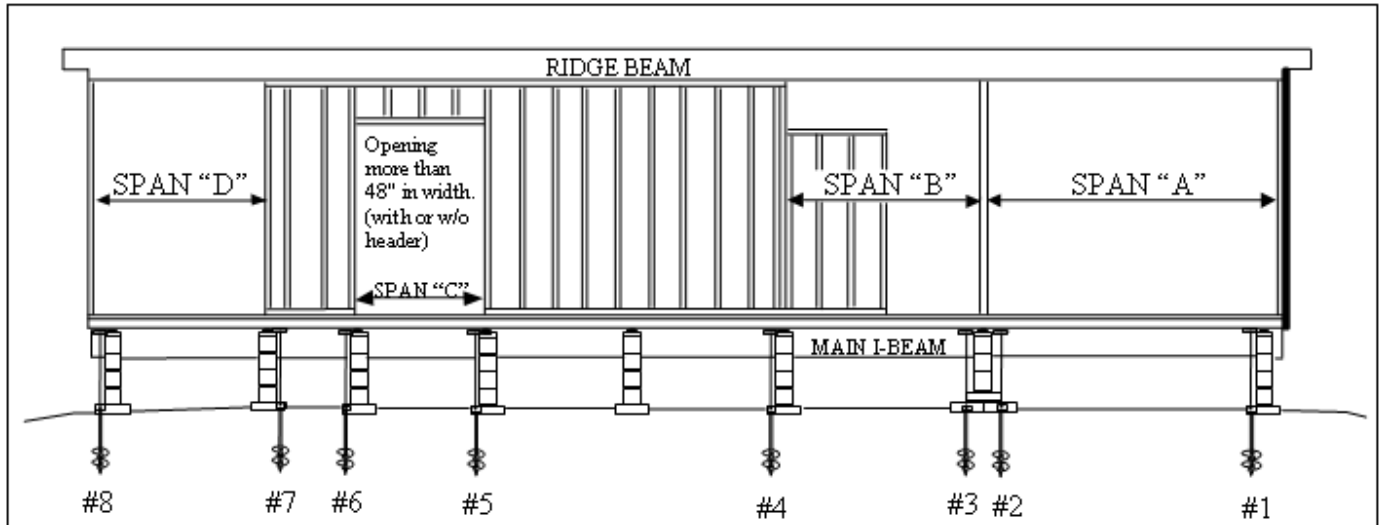

Determine type and number of brackets needed at each opening.

<p>Anchor #1:</p> <p>Anchor #2 & #3:</p> <p>Anchor #4:</p> <p>Anchor #5:</p> <p>Anchor #6 & #7:</p>	<p>From the table in §80.24(f)(4), row 3 in the 14 ft. wide column, the maximum span for this condition is 27'-2". Actual span is 18'-0" ==> one double bracket is ok.</p> <p>Since the wall between spans "A" and "B" is less than 16 inches in width the two spans must be added together to determine number and type of brackets.</p> <p>Span "A" (18'-0") + Span "B" (14'-8") = 32'-8"</p> <p>From the table in §80.24(f)(4), row 3 in the 14 ft. wide column, the maximum span for one double bracket is 27'-2". Actual span is 32'-8" ==> two double brackets required.</p> <p>Span "B" is on both sections @ 14'-8". From the table in §80.24(f)(4), row 3 in the 14 ft. wide column, the maximum span for one double bracket is 27'-2" ==> ok</p> <p>Same as anchor # 4, except for 6'-8" span.</p> <p>This span is on one section only. Therefore a single bracket may be used. From the table in §80.24(f)(4), row 1 in the 14 ft. wide column, the maximum span for a single bracket is 15'-0". Actual span is 13'-8" ==> single bracket is ok.</p>
--	---

- (6) Longitudinal ties:
- (A) Longitudinal ties are required for ALL wind zone installations, regardless of the date of manufacture, when installation occurs after the effective date of these rules.
 - (B) Longitudinal ties are designed to prevent lateral movement along the length of the home.

- (C) When conventional anchors and straps are used; the required number of ties must be installed as appropriate. The strap(s) may be connected or wrapped around front or rear chassis header members, around existing cross members or spring hangers. A strap must be within 3 inches of where the cross member attaches to the main I-beam. Alternatively, brackets to receive the strap(s) may be attached to the bottom flange of the main I-beams. The location of the connection points along the length of the I-beams are not critical, as long as the number of longitudinal ties required for each end of each home section are installed with their pull in opposite directions. No two anchors shall be within 4 ft of each other. No two ties shall be attached to the same structural member of the home, other than a main longitudinal frame member or a front or rear chassis header member.
- (D) Anchors require stabilizer plates when the anchor shaft is not in line with strap (plus or minus 10 degrees).

**§80.25. Generic Standards for Multi-Section Connections Standards.
(Effective: December 25, 2012)**

- (a) Air infiltration and water vapor migration at mating surfaces: Before positioning additional sections, the mating line surfaces along the floor, endwall and ceiling, require material or procedures to limit air infiltration and water vapor migration.
 - (1) Expanding Foam: Foam may be used along surfaces that are accessible after the units have been joined. Where mating line walls line up between sections, non-porous materials must be installed prior to joining the units.
 - (2) Caulking: Caulking may be used along surfaces that are accessible after the units have been joined. Where mating line walls line up between sections, non-porous materials must be installed prior to joining the units.
 - (3) Non-porous gasket installed along the perimeter of all mating lines.
 - (4) Insulation, carpet, carpet pad or other porous materials are not acceptable.

MATING LINE SURFACES

Mating line surfaces are along the floor, up the front and rear endwalls and along the ceiling line.

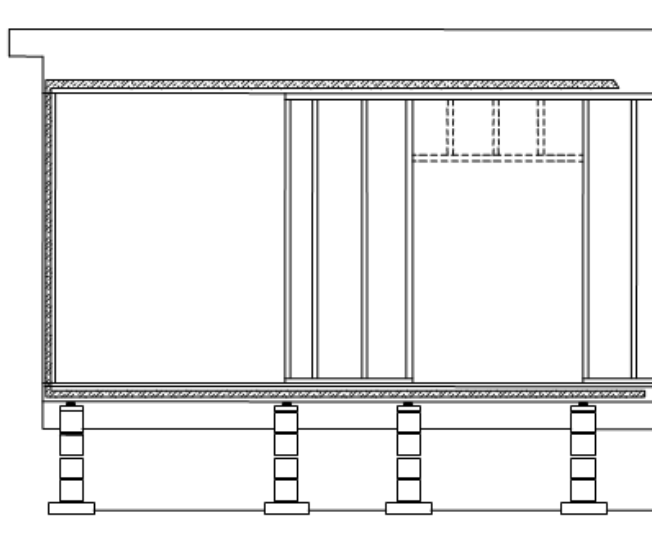

(b) Floor Connections:

- (1) Gaps between floors up to 1-1/2 inches maximum which do not extend the full length of the floor may be filled with lumber, plywood or other suitable shimming materials. Fastener lengths in shimmed areas may need to be increased to provide minimum 1-1/4 inches penetration into opposite floor rim joist.
- (2) Gaps less than 1/2 inch width need not be shimmed.
- (3) The floor assemblies of multi-section units must be fastened together. Fastener options and maximum spacings are listed in the floor connections figure in paragraph (4) of this subsection.
- (4) Any tears or damages to the bottom board due to fastener installation must be repaired.

Wind Zone	min 5/16 lag screw	# 10 wood screw
Wind Zone I	max. 36"	max. 24"
Wind Zone II	max. 24"	max. 12"

FLOOR CONNECTIONS

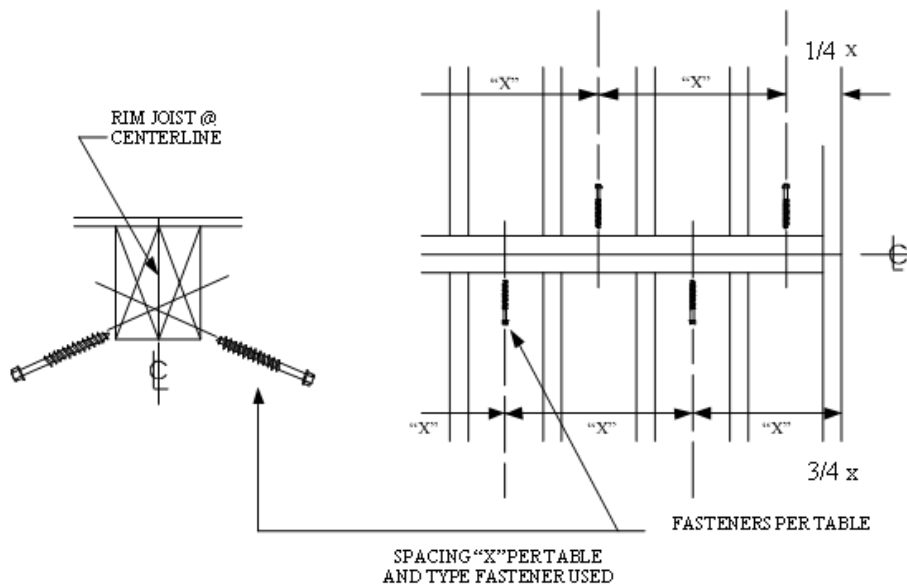

(c) Endwall Connections:

- (1) Endwalls must be fastened together at the mating line with minimum #8x4 inch wood screws or 16d nails at maximum 8 inches on-center or 12 inches on-center maximum for 5/16 lags; toed or driven straight; and
- (2) Fastener length may need to be adjusted for gaps and/or toeing, to provide minimum 1-1/2 inch penetration into opposite endwall stud.

ENDWALL CONNECTIONS

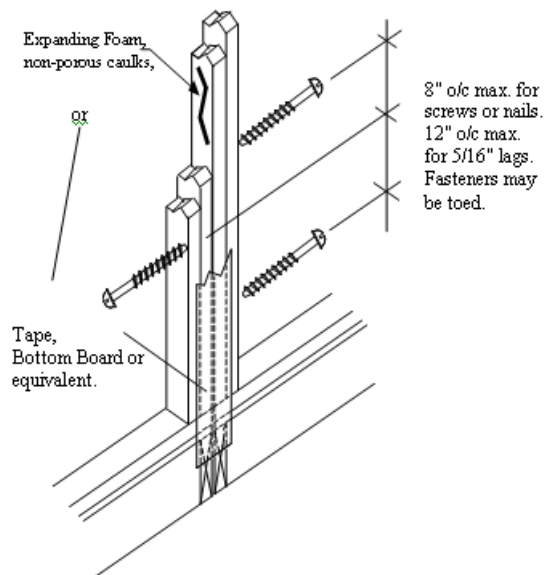

(d) Roof Connection: (Note: Fasteners must not be used to pull the sections together.)

(1) Roof shall be connected with the fasteners and spacings specified in the figure in paragraph (2) of this subsection.

(2) Gaps between the roof sections (at ridge beam and/or open beam ledgers) of up to 1-1/2 inches wide maximum which do not extend the full length of the roof must be filled with lumber and/or plywood shims. Gaps up to 1/2 inch need not be shimmed. The fastener length used in the shimmed area may need to be increased to provide a minimum 1-1/4 inch penetration into the adjacent roof structural member.

Roof Connection - Fastener type and spacing:

----- maximum o.c. spacing (in) -----

Wind Zone	3/8 Lag	1/4 Lag	#10 wood screw
Wind Zone I	36"	24"	24"
Wind Zone II	20"	16"	12"

ROOF CONNECTION

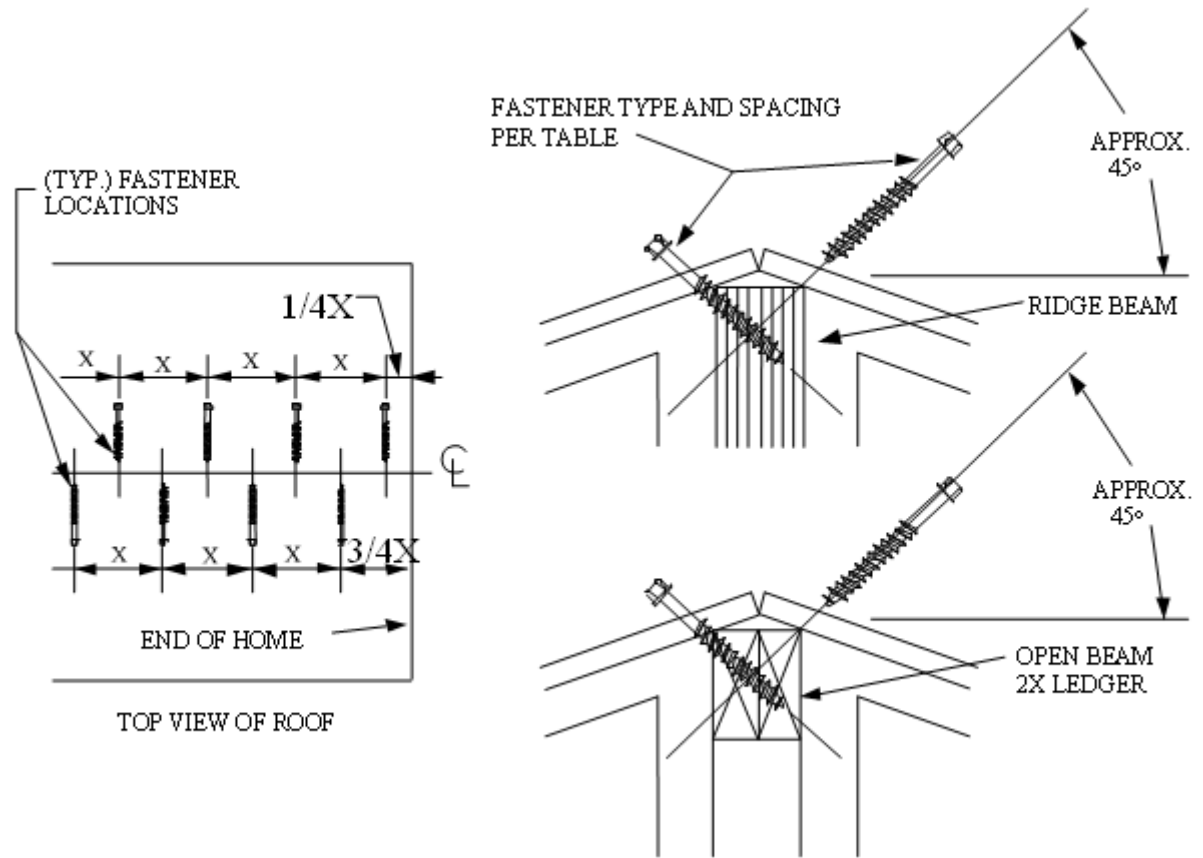

(e) Exterior Roof Close Up:

- (1) Ensure that shingles are installed to edge of roof decking at peak. Follow nailing instructions on the shingle wrapper. Note: Wind Zone II (high wind) installations require additional fasteners.
- (2) Before installing ridge cap shingles, a minimum 6 inch wide piece of 30 gauge galvanized flashing must be installed the length of the roof.
- (3) When flashing is not continuous, lap individual pieces a minimum of 6 inches.
- (4) Fasten flashing into roof sheathing with minimum 16 gauge staples with 1 inch crown or roofing nails of sufficient length to penetrate roof decking. Maximum fastener spacing is 6 inches on-center each roof section. Place fasteners a minimum of 3/4 inches along edge of flashing.
- (5) Install ridge shingles directly on top of flashing.
- (6) Check and repair as necessary the remainder of roof for any damaged or loose shingles, remove any shipping plastic or netting, wind deflectors, etc. Make sure to seal any fastener holes with roofing cement.

EXTERIOR ROOF CLOSE UP

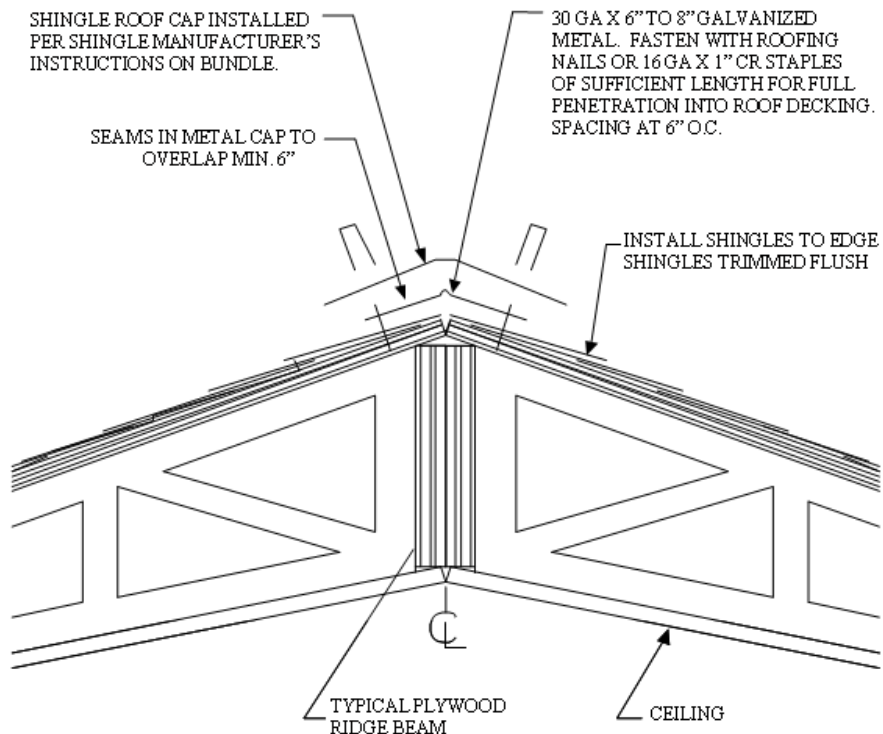

- (f) Exterior Endwall Close Up: Cut closure material to the shape and size required and secure in place, starting from the bottom up, *i.e.*: bottom starter, vertical or horizontal siding, then roof overhang, soffit and fascia. All closure material should be fitted and sealed as required to protect the structure or interior from the elements.

- (g) HVAC (heat/cooling) Duct Crossover:
 - (1) Crossover duct must be listed for EXTERIOR use.
 - (2) Duct R-value shall be a minimum of R-4.
 - (3) The duct must be supported 48 inches on-center (maximum) and must not be allowed to touch the ground. Either strapping (minimum 1 inch wide), to hang the duct from the floor, or non-continuous pads to support it off the ground are acceptable.
 - (4) The duct to the collar or plenum connections must be secured with bands or straps designed for such use. Keep duct as straight as possible to avoid kinks or bends that may restrict the airflow. Extra length must be cut off.
 - (5) The installer should refer to the manufacturer's instruction for assembling the overhead duct.

HVAC (HEAT/COOLING) DUCT CROSSOVER

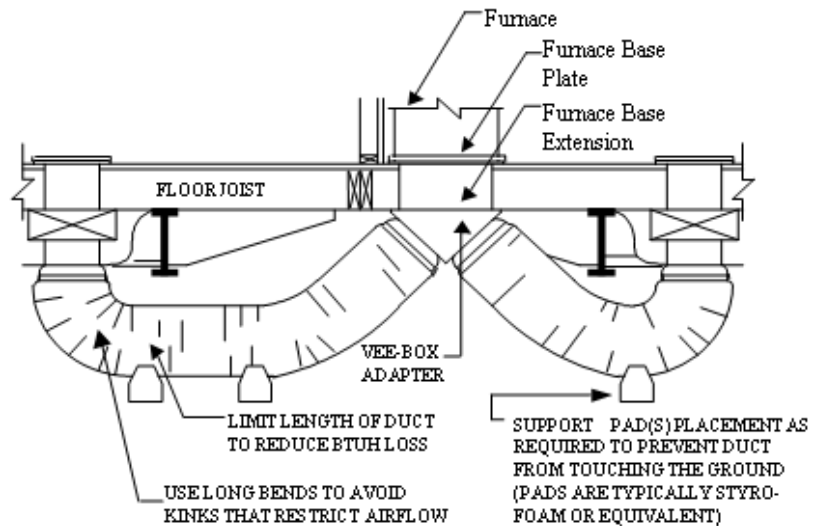
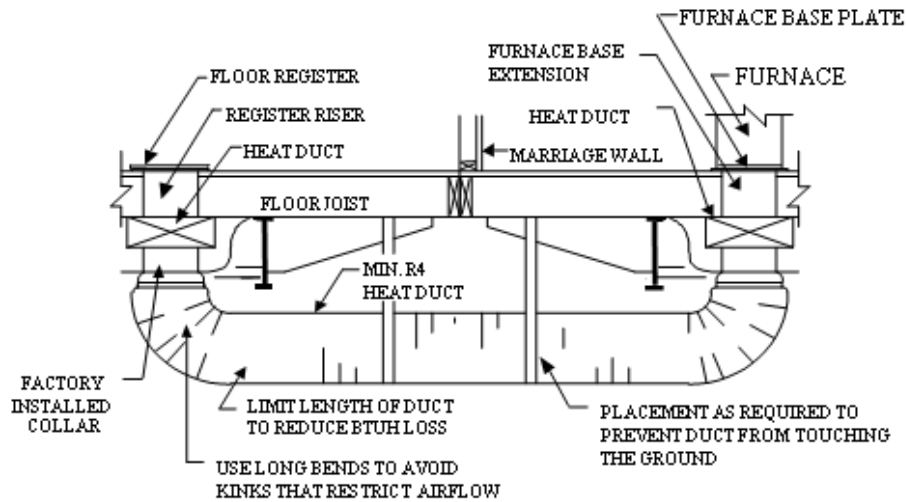

(h) Multi-Section Water Crossover:

- (1) If there is water service to other sections, connect the water supply crossover lines as shown in the applicable detail.
- (2) If the water crossover connection is not within the insulated floor envelopes, wrap the exposed water lines in insulation and secure with a good pressure sensitive tape or nonabrasive strap, or enclose the exposed portion with an insulated box.
- (3) If water piping at the inlet is exposed, a heat tape should be installed to prevent freezing. A heat tape receptacle has been provided near the water inlet. When purchasing a heat tape, it must be listed for

manufactured home use, and it must be installed per manufacturer's instructions.

MULTI-SECTION WATER CROSSOVER CONNECTIONS

METHOD A

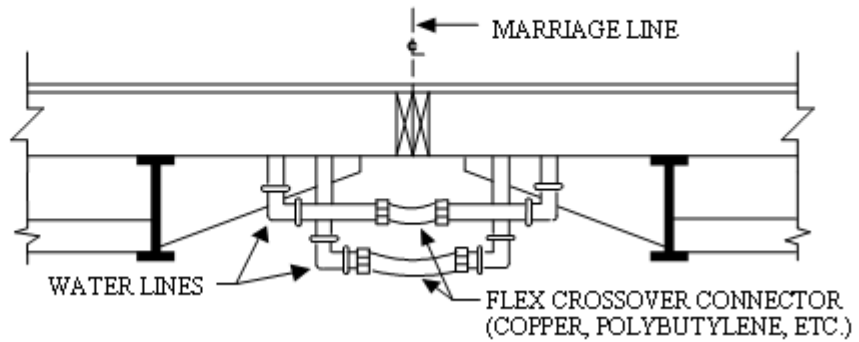

METHOD B

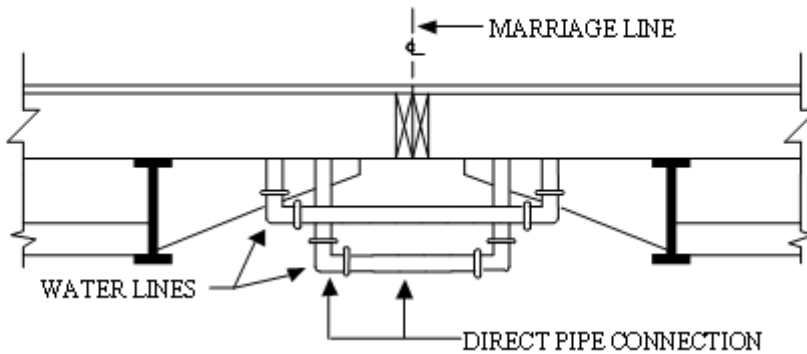

METHOD C

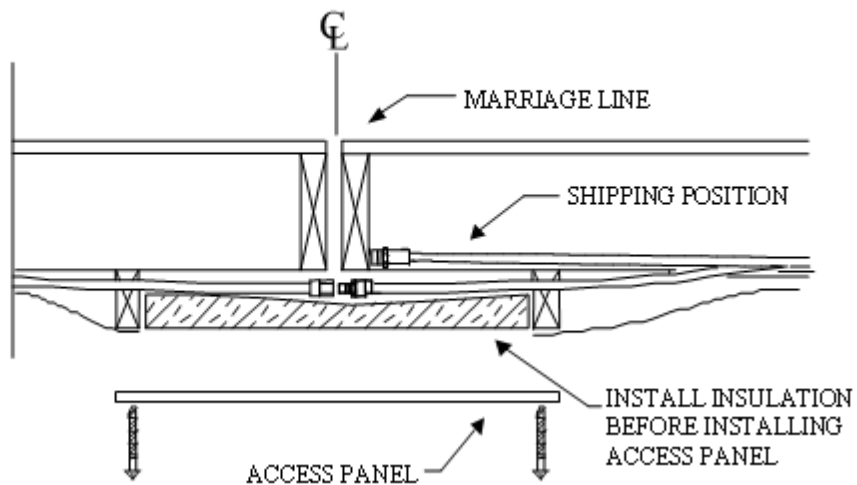

(i) Drain, Waste and Vent System (DWV):

- (1) Portions of the DWV system which are below the floor may not have been installed, to prevent damage to the piping during transport. Typically, the DWV layout is designed to terminate at a single connection point to connect to the on-site sewer system. For a used home where on-site DWV connections are not assembled per the manufacturer's instructions, the DWV system must be assembled in accordance with Part 3280 of the FMHCSS.

DRAIN, WASTE AND VENT FLOOR PIPING SYSTEM

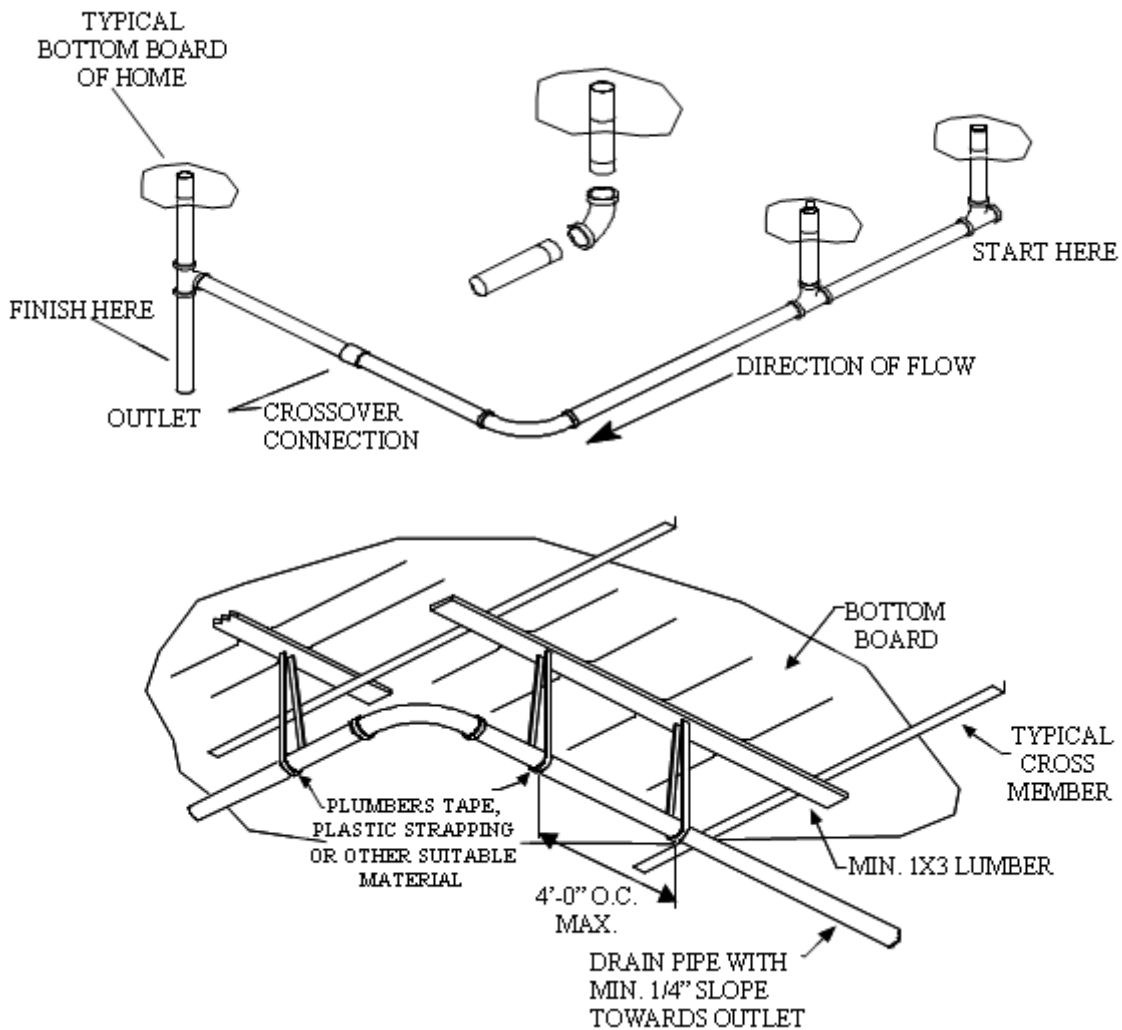

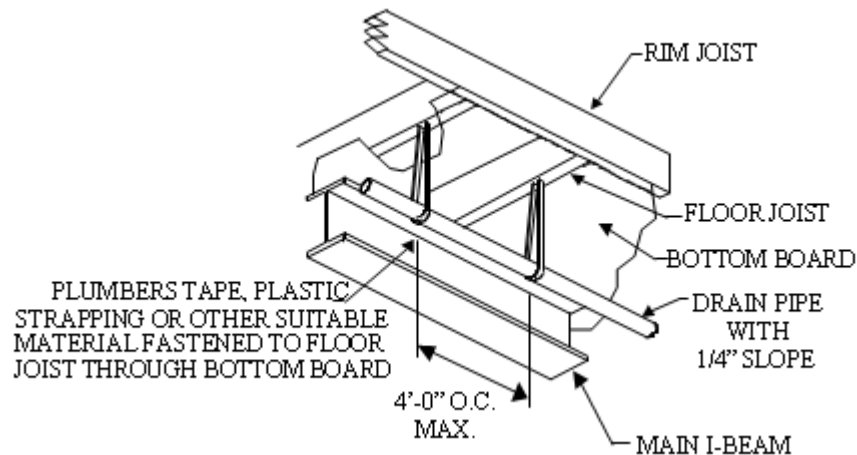

(2) The following guidelines apply:

- (A) All portions of the DWV system shall be installed to provide a minimum of 1/8 inch slope per foot for a 3 inch diameter pipe or larger, in the direction of the flow. For all other pipe, a minimum of 1/4 inch is required.
 - (B) Changes in direction from vertical to horizontal, and horizontal to horizontal, shall be made using long sweep elbows and/or tees.
 - (C) All drain piping shall be supported at intervals not to exceed 4 feet on-center. The support may be either blocking or strapping. When strapping is used, it should be nonabrasive.
 - (D) Piping must be assembled with the appropriate cleaners, primers and solvents (note: both ABS and PVC systems are common, but will require adhesives). Be sure to follow the instructions of the product used.
 - (E) A cleanout must be installed at the upper (most remote) end of the floor piping system.
- (3) Water testing: At the time of installation the water system must be inspected and tested for leaks after completion at the site (the water heater must be disconnected when using an air-only test).
- (4) Drainage system testing: At the time of installation the drainage system must be inspected and tested for leaks after completion at the site.
- (j) Electrical Connections: Depending on the model and/or manufacturer of the home, electrical crossovers may be located in either the front end and/or rear end of the home. Check along mating line for other labeled access panels.
- (1) Crossover connections may be one of the following:

- (A) snap or plug-in type;
 - (B) junction boxes inside floor cavity (note: crossover wiring routed outside the floor cavity must be enclosed in conduit). If the boxes and/or covers are metal, they must be grounded by the use of the ground wire; or
 - (C) pigtail between receptacles/switches between sections (one circuit only and enclosed in a j-box according to the National Electrical Code (NEC).
- (2) Chassis Bonding: Each chassis shall be bonded to the adjacent chassis with a solid or stranded, green insulated or bare, number 8 copper conductor. The conductor is connected to the steel chassis with a solderless lug. *Alternate bonding: A 4 inch wide by 30 gauge continuous metal strap may be used as an alternate, when attached to the chassis members with two #8x 3/4 inch self tapping metal screws each end of the strap.*

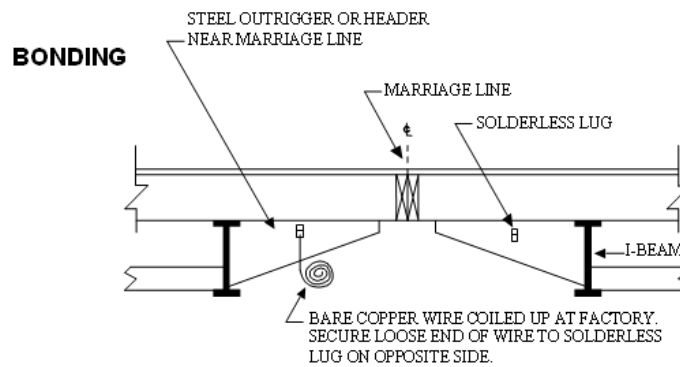

NOTE:
 A 4" BONDING STRAP MAY BE USED INSTEAD OF COPPER WIRE BY ATTACHING THE STRAP TO BOTH UNITS WITH 2-#8X3/4" SELF-TAPPING METAL SCREWS ON EACH SIDE.

(3) Electrical Crossover.

ELECTRICAL CROSSOVER

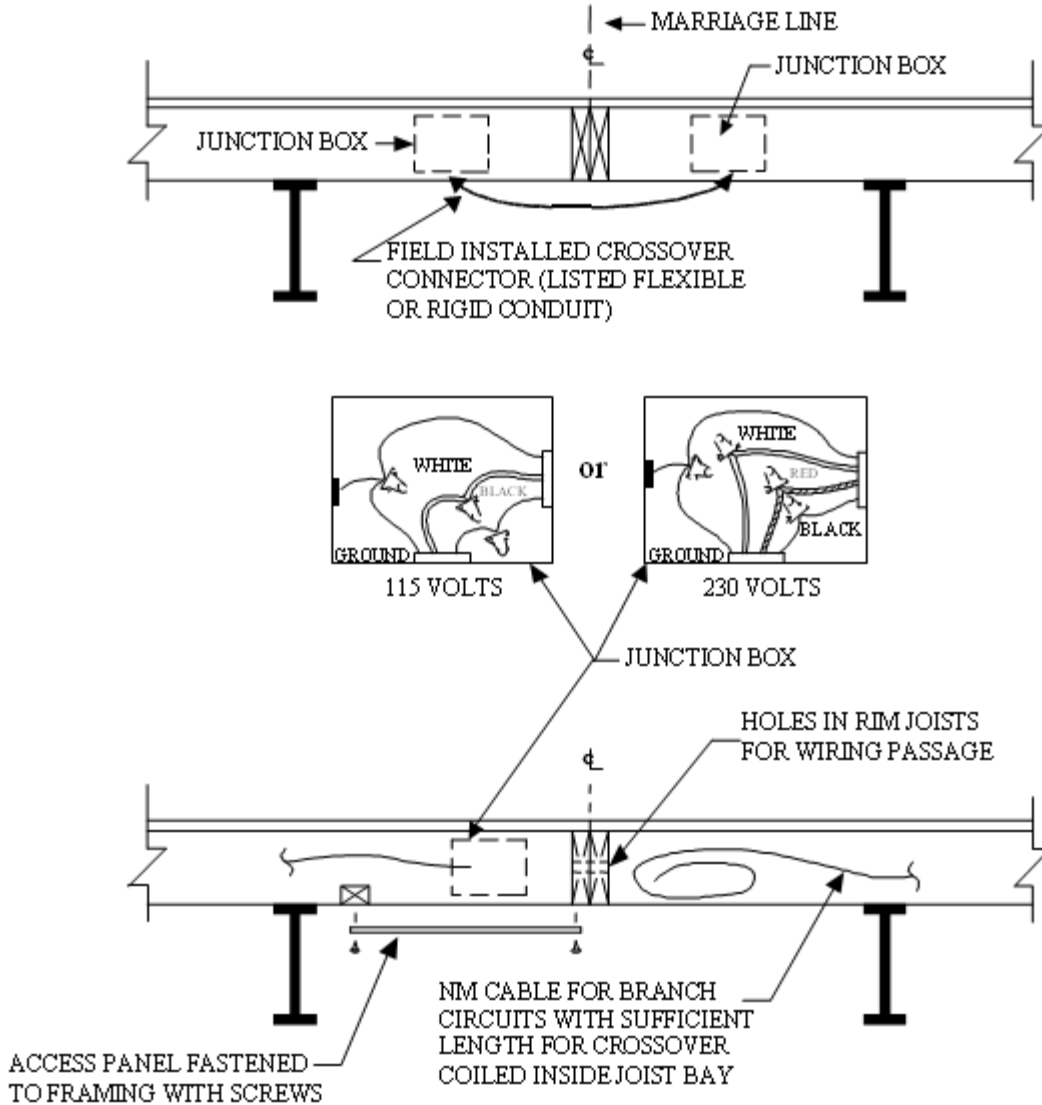

NOTE:
ANY EXPOSED NM CABLE MUST BE PROTECTED BY CONDUIT AND INSTALLED IN ACCORDANCE WITH THE N.E.C.

(4) Shipped loose equipment:

- (A) Electrical equipment such as ceiling fans, chandeliers, exterior lights, etc., which may have been shipped loose, must be installed in accordance with the adopted (NEC). Connect all corresponding

color coded or otherwise marked conductors per the applicable sections of the NEC.

- (B) Bonding strap removal: 240 volt appliances (range, dryer, etc.) shall have the bonding strap removed between the ground and the neutral conductors. Cords used to connect those appliances shall be four conductor, four prong.

- (5) Main panel box feeder connection: The main panel box is wired with the grounding system separated from the neutral system (4-wire feeder). The grounding bus in the panel must be connected through a properly sized green colored insulated conductor to the service entrance equipment (meter base) located on or adjacent to the home. A licensed electrician is required to run the feeder from the pole to the main panel box in the home.

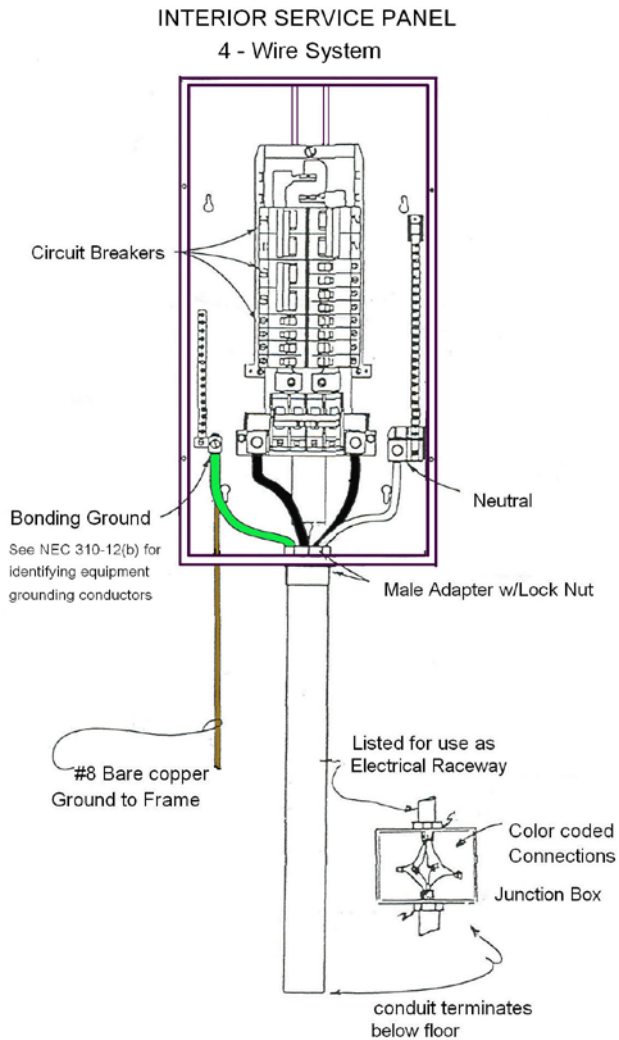

MAIN PANEL BOX FEEDER CONDUCTOR SIZES

Main Breaker size (amps)	Raceway diameter	Red/Black (power)	White (neutral)	Green (grounding)
50	1	#6	#6	#8
100	1 1/4	#2 or #3	#2 or #3	#6
150	1 1/2	#1/0 or #2/0	#2	#6
200	2	#3/0	#2	#6

(k) Fuel Gas Piping Systems:

- (1) Crossover Connections: All underfloor fuel gas pipe crossover connections shall be accessible and be made with the connectors supplied by the home manufacturer, or, if not available, with flexible connectors listed for exterior use and a listed quick disconnect (Method A), or a shut-off valve (Method B). When shut-off valve is used, it must be installed on the supply side of the gas piping system. The crossover connector must have a capacity rating (BTUH) of at least the total BTUH's of all appliances it serves.
- (2) Testing: The fuel gas piping system shall be subjected to an air pressure test of no less than 6 ounces and no more than 8 ounces. While the gas piping system is pressurized with air, the appliance and crossover connections shall be tested for leakage with soapy water or bubble solution. This test is required of the person connecting the gas supply to the home, but may also be performed by the gas utility or supply company.
- (3) The gas system must be inspected and tested for leaks after completion at the site.

FUEL GAS PIPE CROSSOVER CONNECTIONS

Method A

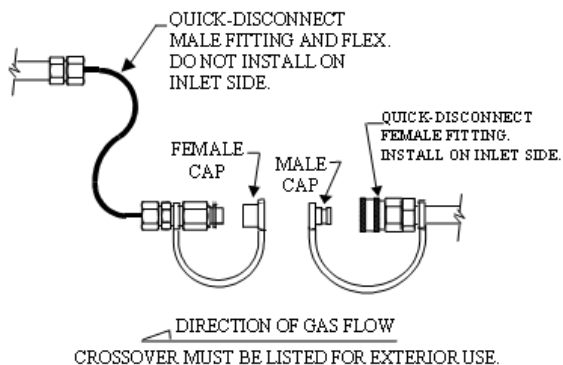

Method B

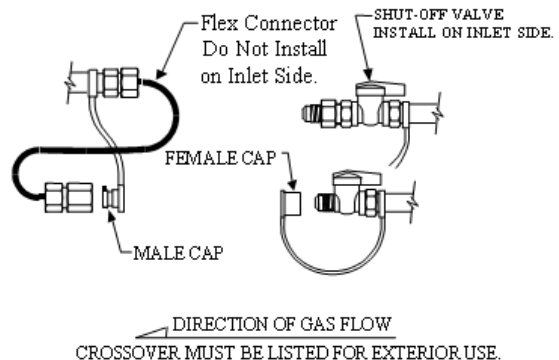

§80.26. Registration of Stabilizing Components and Systems.
(Effective: January 29, 2008)

- (a) Installers shall use only prefabricated or site built stabilizing components and systems which are:
 - (1) registered with the Department,
 - (2) specified by the home manufacturer's DAPIA approved installation instructions, or
 - (3) specified for one or more homes in a particular area by a Texas licensed engineer or architect.

- (b) Before accepting a registration of any prefabricated stabilizing component or system that will be used for more than one home or granting renewal of such, the Department will require the component or system to be certified by an engineer, architect, or independent testing laboratory. The engineer or architect may be licensed in any state. The independent testing laboratory must have at least one engineer or architect licensed in at least one state. The producer or vendor of the component or system must send a request letter to the Department with at least two copies of the certification report. The Department may accept certification reports in electronic formats. The certification report copies must have letter size (8.5 inch by 11 inch) or smaller pages. The producer or vendor must provide written permission to the Department to reproduce the certification report. If the Department accepts the registration of the certification report, the Department shall place a registration stamp on the copies, keep one copy, and return all other stamped copies to the producer or vendor. The registration stamp will include the following information:
 - (1) the title "Texas Department of Housing and Community Affairs" Manufactured Housing Division;
 - (2) the phrase "Registered stabilizing component or system"; and
 - (3) the date of registration.

- (c) The Department will maintain a list of stabilizing components and systems that have been registered with the Department for use in Texas and will post a current copy of the list on the Department's website.

- (d) A report that certifies a stabilizing component or system shall contain, at the minimum, the following:
 - (1) the name, address, phone number, facsimile number, and trademark of the agency issuing the certification report or the name, signature, license

- number, state where licensed, address, phone number, facsimile number, and seal of the engineer or architect;
- (2) date of certification report;
 - (3) the name, address, phone number, and facsimile number of the vendor or producer of the component or system;
 - (4) drawing or photograph of component or system;
 - (5) a description of the vendor's or producer's method for identifying the component or system;
 - (6) at least a 2 inch by 4 inch blank space for the Department registration stamp on each page or the cover page of a bound document;
 - (7) a unique number or other identification for the certification report;
 - (8) the initial qualifying test report or information about how the report can be obtained;
 - (9) a description of the continuing validation system and the time period of the certification;
 - (10) detailed and specific installation instructions for the component or system, a copy of which that are shipped to each purchaser;
 - (11) a description of the working load capacity for the component or system. If the component is a ground anchor, the anchor shall be certified by a professional engineer, architect or nationally recognized testing laboratory as to its resistance, based on the maximum angle of diagonal tie and/or vertical tie loading and angle of anchor installation, and type of soil in which the anchor is to be installed;
 - (12) a description of all allowable conditions for use of the component or system such as (but not limited to) types of soil, weather exposure, atmospheric environment (rural, industrial, coastal), and characteristics of other associated components; and
 - (13) a statement that the certifying independent testing laboratory, certifying engineer, or certifying architect certifies the component or system to be in conformance with all applicable standards adopted by the Department. This statement shall be on each page or shall be on the cover sheet of a bound document.

- (e) The Department adopts the applicable standards and publications set forth in Chapter 43 of the International Code Council, latest edition of the International Residential Code for materials used to fabricate stabilizing components and systems. The Department adopts the stabilizing component destruction test failure criteria of the FMHCSS (24 CFR, Part 3280) or latest edition of the International Residential Code, Appendix E.
- (f) Applicable reports of the following organizations are acceptable as certification reports: National Evaluation Service, Inc.; International Conference of Building Officials (ICBO) Evaluation Service, Inc.; Southern Building Code Congress International (SBCCI) Public Safety Testing and Evaluation Services, Inc.; Building Officials and Code Administrators International (BOCA) Evaluation Reports, Inc.; the International Code Council (ICC); or a successor of any of these organizations.
- (g) The Department may deny registration if the certification information:
 - (1) is incomplete;
 - (2) does not conform to the rules of the Department;
 - (3) contradicts the qualifying tests; or
 - (4) has contradictory statements.
- (h) Conditions that may cause the Board to issue an administrative order that withdraws registration from a stabilizing component or system may include but are not limited to:
 - (1) the engineer, architect, or independent testing laboratory withdraws the certification;
 - (2) the engineer, architect, or independent testing laboratory improperly certified the component or system;
 - (3) a significant characteristic of a device or system has been changed without a revision of the original certification;
 - (4) the producer distributes installation instructions that are substantively different from those in the certification or original qualifying tests;
 - (5) changes in the law, rules, or standards;
 - (6) the continuing validation system for a component has been changed without a revision of the original certification;
 - (7) information provided by the original certification is obsolete;

- (8) the Department receives evidence that the component or system often fails to anchor or support the home; or
- (9) the producer fails to provide test results after the Department directs the producer to test the component or system. The test will be performed by a recognized independent testing laboratory under the observation of a qualified representative or designee of the Department.
- (i) Notice of withdrawal of registration of a component or system must be given to the producer and to all licensed installers, retailers, and manufacturers.
- (j) The Department's registration of a stabilizing component or system is valid for a period of ten (10) years or for the time period of certification, whichever is less. The registration expires at the end of the shorter period.
 - (1) If the time period for certification exceeds the ten (10) year registration period, the producer of the stabilizing component or system may apply for a renewal of the registration. The renewal shall be valid for an additional period:
 - (A) of ten (10) years; or
 - (B) if the time period of certification expires prior to the end of the ten (10) year period, for a lesser period ending with the expiration of the time period of certification.
 - (2) All Department approval letters issued prior to November 3, 1998, remain valid for a period of ten (10) years following the original effective date of this section and expire on November 3, 2008, or upon any previously assigned expiration date if that date is earlier.
- (k) A registration renewal request must be received from the vendor or producer of the component or system at least ninety (90) calendar days prior to the date the certification or registration expires. The request must supply the information necessary for the Department to issue a registration renewal.
- (l) Registered components and systems sold to retailers or installers prior to the expiration of the applicable registration or renewal may be used and installed for a period of not more than ninety (90) calendar days following the date of expiration of their approval, registration, or renewal.
- (m) Advertisements and instructions may not express or imply that the component or system has Department approval.

SUBCHAPTER C. LICENSEES' RESPONSIBILITIES AND REQUIREMENTS

§80.30. All Licensees' Responsibilities. (Effective: October 23, 2022)

- (a) A licensee, other than a salesperson, must maintain all required records at a location that meets the requirements of §1201.103(a-1) of the Standards Act. All records required by this chapter must be maintained in the licensee's files for a period of not less than six (6) years. Unless stated otherwise, a record of any disclosure to be given shall reflect that it was properly completed, executed, and dated. Files may be maintained in an electronic format, as long as they can be produced upon request by the Department for review.
- (b) A licensee must keep the Department advised in writing on a current basis of any changes in their licensing information and, where required by the Standards Act, give prior written notice.
- (c) If a licensee fails to provide any warranty listed in this subsection of the rules, the time limitations associated with the consumer's written notification do not start until the consumer is provided with such required warranty.
- (d) A license holder is prohibited from publishing or distributing any form of advertising which is false, deceptive, or misleading.
- (e) Any advertisement must comply with applicable federal and state legal requirements, including, but not limited to, the federal Truth in Lending Act and Federal Reserve Regulation Z.
- (f) Any advertisement (including social media) by a retailer, broker, or installer (other than a sign/display advertisement at a licensed location, point of sale literature, or a price tag) must conspicuously disclose the license number of the person who is advertising.
- (g) Any advertisement (including social media) by a salesperson must conspicuously disclose the name and license number of their sponsoring retailer identified on their valid salespersons license.
- (h) Where no consumer protection purposes would be served by requiring the license number to be disclosed, the Board may grant exceptions to subsections (f) and (g) of this section based on the Board's approved format. Exceptions will be posted on the Department's website.
- (i) Any licensee's website shall provide a conspicuously placed link to the Department's website.

§80.31. Manufacturers' Responsibilities and Requirements.
(Effective: November 6, 2011)

- (a) A manufacturer shall submit a monthly shipment report to the Department of all manufactured homes produced during the preceding month for shipment to any point in Texas. The report shall contain the following information:
 - (1) the complete HUD label number(s);
 - (2) the complete serial number(s);
 - (3) the license number of the retailer to whom the home is sold and the location to which it is initially shipped; and
 - (4) a designation as to single or multiple sections.
- (b) The manufacturer's monthly shipment report shall be filed with the Department by the 20th day of the month following the earlier of manufacture of the home and/or shipment. If a manufacturer has no sales or shipments to any person in the State of Texas during any month, the report must be filed stating such fact.
- (c) A manufacturer shall use the Manufacturer's Certificate of Origin (MCO) prescribed by the Department set forth on the Department's website for homes sold to retailers in Texas, on the reverse side of which shall be the data plate.
- (d) A manufacturer shall supply to the Department current and revised copies of approved installation manuals as required by §80.20 of this chapter (relating to Requirements for Manufacturer's Designs and Installation Instructions).
- (e) The term of a required warranty does not begin to run until a warranty that complies with the Standards Act is actually delivered.

§80.32. Retailers' Responsibilities and Requirements.
(Effective: January 7, 2018)

- (a) A retailer shall retain as a record of each sale a file for that sale containing a completed Retail Monitoring Checklist on the prescribed form, together with copies of all completed, executed, and signed applicable documents specified therein.
- (b) At the time of signing a contract for the sale of a manufactured home, the retailer must disclose to the purchaser, a notice of the existence of a Dispute Resolution Program through HUD, either on a separate document from the sales contract or it may be incorporated clearly at the top of the sales contract. Disclosure of this requirement should be acknowledged by the consumer.

- (c) A retailer shall timely provide each consumer who acquires a manufactured home by sale or exchange with the applicable warranty or warranties specified in the Standards Act and any warranty regarding the home itself shall specify whether the warranty includes cosmetic items or not and, if it does include them, whether there are any limitations or special requirements, such as a walk-through punch lists, excluded items, or the like.
- (d) For each manufactured home taken into a retailer's inventory, a retailer shall maintain a copy of either a completed and timely submitted application for a statement of ownership to reflect the home as inventory or, once such a statement of ownership has been issued and received, a copy of that statement of ownership.
- (e) For each home altered or rebuilt from salvage a retailer shall retain the documentation required for rebuilding a manufactured home that is declared salvaged.
- (f) A retailer must provide their company name, license number, contact information on any sales agreement, and proof of purchase or confirmation of sale.
- (g) If a retailer relies on a third party, such as a title company or closing attorney, to file with the Department the required forms necessary to enable the Department to issue a Statement of Ownership to a consumer, the retailer must provide an instruction letter to that third party, advising them of their responsibilities to make such filings and the required timeframes therefore. This does not relieve the retailer from responsibility. The retailer must retain with their sale records a copy of that instruction letter and all documentation provided to such third party to enable them to make such filings. This optional form is available on the Department's website.
- (h) On a new manufactured home and on any used manufactured home where the sale or exchange includes installation, the retailer must specify in the applicable contract or an accompanying written disclosure the intended date by which installation will be complete and a designated person to contact for the current status as to the intended date for completion of installation. For new manufactured homes, the retailer is responsible for ensuring that a licensed installer warrants the proper installation of the home and performs the required site preparation.
- (i) If any goods or services being provided by a retailer in connection with the sale and/or installation of a manufactured home, the retailer must disclose, in writing, the goods and/or services to be provided and a good faith estimate as to when they will be provided.

- (j) If any goods with a retail value of more than \$250 are to be provided in connection with the sale of a manufactured home and they are not specified on the data plate for the home, the retailer must describe them in the retail installment contract, purchase memorandum, or other sale document in sufficient detail to enable a third party to provide them under the responsibility of the retailer's surety bond should the retailer fail to provide them as agreed.
- (k) A retailer accepting a deposit must give the consumer a written statement setting forth:
 - (1) the amount of such deposit;
 - (2) a statement of any requirements to obtain or limitations on any such refund; and
 - (3) the name and business address of the person receiving such deposit.
- (l) A retailer may not represent to a consumer that is purchasing a manufactured home with interim financing that the consumer will qualify for permanent financing if the retailer has any reason to believe that the consumer will not qualify for such permanent financing.
- (m) A retailer may not increase the advertised price at which a manufactured home is to be sold based on the consumer's decision to make the purchase with or without financing provided by or arranged through the retailer.
- (n) A retailer may not request or accept any document that is executed in blank or allow any alteration to a completed document without the consumer's initialing and dating such changes to indicate agreement to them. Where information is not available, a statement of that fact (*e.g.*, TBD – to be determined, not available, N/A, not applicable, or the like) may be entered in the blank. A consumer must be provided with copies of all documents they execute.
- (o) A retailer may not knowingly accept or issue any check or other form of payment appearing on its face to be a *bona fide* payment but known not to represent good funds.
- (p) In order to comply with the provisions of §1201.107(d) of the Standards Act, a retailer or broker must:
 - (1) have a current, in effect surety bond issued in the most recent form promulgated by the Department; and
 - (2) the applicable sales agreement must identify the surety bond that applies to the transaction and contain the following statement: "The above-described surety bond applies to this transaction in the following

manner: The bond is issued to the Texas Manufactured Homeowner Consumer Claims Program (the "Claims Program"), the Claims Program described in the Texas Manufactured Housing Standards Act (Tex. Occ. Code, Chapter 1201) and administered by the Department. If the Claims Program makes a payment to a consumer, the Claims Program will seek to recover under the surety bond. The obligation of the Claims Program to compensate a consumer for damages subject to reimbursement by the Claims Program is independent of the Claims Program's right or ability to recover from the above-described surety bond, but recoveries on surety bonds are an important part of the Claims Program's ability to maintain sufficient assets to compensate consumers. There can be no assurance that the Claims Program will have sufficient assets to compensate a consumer for a covered claim. Assuming it has sufficient assets to compensate a consumer for a covered claim, the liability of the Claims Program is limited to actual damages, not to exceed \$35,000."

- (q) A retailer shall maintain on a current basis a separate file for each salesperson sponsored by that retailer reflecting:
 - (1) that they are licensed in accordance with the Standards Act;
 - (2) the date of the initial licensing class that they attended and a copy of their certificate of completion;
 - (3) evidence of the successful completion of any required continuing education classes that they attended; and
 - (4) a copy of any written notice to the Department that sponsorship was terminated and the effective date thereof.
- (r) At each licensed location a retailer shall display their current license for that location and the current license of each salesperson who works from that location.
- (s) At each licensed location a retailer shall conspicuously display the Consumer Protection Information sign as set forth on the Department's website.
- (t) Auction of Manufactured Housing to Texas Consumers.
 - (1) A person selling more than one home to one or more consumers through an auction in a twelve (12) month period must be licensed as a retailer, each individual acting as their agent must be licensed as a salesperson, and each specific location at which an auction is held must be licensed and bonded in accordance with the Standards Act.

- (2) Acting as an auctioneer may be subject to the Texas Auctioneer Act, Occupations Code, Chapter 1802.
- (3) The retailer must notify this Department in writing at least thirty (30) calendar days prior to the auction with such notice to contain the date, time, and physical address and location of a proposed auction or, if they recur on a scheduled basis, of the schedule.
- (u) A person may exercise their right of rescission of contract for sale or exchange of home pursuant to §1201.1521 of the Standards Act within three (3) business days without penalty or charge.
- (v) The written warranty that the used manufactured home is habitable as per §1201.455 of the Standards Act, shall have been timely delivered if given to the homeowner at or prior to possession or at the time the applicable sales agreement is signed.
- (w) The written manufacturer's new home construction warranty per §1201.351 of the Standards Act, shall be timely delivered if given to the homeowner at or prior to the time of initial installation at the consumer's home site.

§80.33. *Installers' Responsibilities and Requirements.*
(Effective: January 7, 2018)

- (a) If the retailer subcontracts installation to another licensed installer, their respective responsibilities are as set forth in the Standards Act.
- (b) For used manufactured homes, the person contracting with the consumer for the installation of the home is the installer and must warrant the proper installation of the home. If the contracting installer subcontracts with an independent licensed installer, then the subcontractor is jointly and severally liable for that portion of the installation that the subcontractor performed.
- (c) A person contracting directly with the consumer for only the transportation of a manufactured home to its site is not deemed by virtue of being the transporter to also be the installer.
- (d) The contracting licensed installer is fully responsible for the complete installation in accordance with all applicable requirements set forth in this chapter even though the installer may subcontract certain installation functions to independent contractors pursuant to §1201.102(b) of the Standards Act. It is unlawful for a subcontractor who is acting as an agent for a licensed installer to advertise and/or offer installation services to any person unless the licensed installer's name and license number appear conspicuously in the advertisement.

- (e) A person contracting for the installation of a manufactured home must specify in the applicable contract or an accompanying written disclosure the intended date by which installation will be complete and a designated person to contact for the current status as to the intended date for completion of installation.
- (f) An installer shall provide the Department with a list of all subcontractors approved to work under the installer's license number.
- (g) For each installation completed, the installer must complete a Notice of Installation and submit the original, signed form with the required fee to the Department no later than seven (7) days after which the installation is completed, but not later than three (3) days for installers with a provisional license. If an installer submits multiple installation reports at one time, a single payment for the combined fees may be submitted.
 - (1) If a contracting installer subcontracts the installation to a licensed installer, the subcontracted installer who performs the installation shall complete the Notice of Installation, and submit the original signed form to the Department no later than seven (7) days after which the installation is completed, or not later than three (3) days for installers with a provisional license. The subcontracted installer may submit the required fee with the Notice of Installation Form.
 - (2) If a contracting installer subcontracts the installation to a licensed installer, and the subcontracted installer does not pay the fee, the contracting installer shall submit a copy of the Notice of Installation, labeled as such, with the required fee to the Department no later than seven (7) days after which the installation is completed, or not later than three (3) days for subcontracted installers with a provisional license.
 - (3) Provisional installers that provide the installation are required to send a copy of the Notice of Installation to the Department's Field Office within three (3) days of the installation to ensure a timely inspection may be conducted.
 - (4) The timely submittal of the Notice of Installation after completion of the installation ensures the Department inspectors may inspect the manufactured home with utilities connected, but before the home is skirted.
- (h) The completed Notice of Installation may, within the time frames specified in subsection (g) of this section be submitted with an application for Statement of Ownership but is not a requirement to obtain a Statement of Ownership. Copies must be labeled as such. The licensed installer who is listed on a Notice of Installation is presumed to be the installer primarily responsible for the

installation and the person to whom any warranty orders, notices of inspection, or other communications from the Department regarding the installation shall be directed.

- (i) Electrical, fuel, mechanical, and plumbing system crossover connections for multi-section homes, and completion of drain lines underneath all homes in accordance with the requirements of this chapter and installation of steps or legally compliant ramps to any exterior door that will be 12 inches or more above ground level are installer responsibilities and cannot be excluded by wording of the installation contract when provided by or installed by the installer. The installation of air conditioning at the home site must be performed by a licensed air conditioning contractor. The installation and ventilation of skirting or other material that encloses the crawl space underneath a manufactured home is an installer responsibility, if it is part of the sales or installation contract.
- (j) A checklist must be maintained in the files. The checklist must consist of the following:
 - (1) the HUD label number or Texas seal number and the serial number;
 - (2) verification of the soil condition(s) at the installation site;
 - (3) if installed on piers or pads, verification of the calculation of pier spacing; and
 - (4) a list of each approved component or device used in the installation.
- (k) Each installer shall maintain the following books and records for each installation:
 - (1) verification that the required site preparation notice for a used home was signed by the consumer and timely delivered to a consumer by the licensee;
 - (2) a copy of each installation warranty provided to a consumer with evidence that the warranty was timely delivered to the consumer;
 - (3) if the used home is to be installed on a site that has evidence of ponding, run-off, or uncompacted soil, a signed form from the consumer, acknowledging the condition and accepting the risks, such form to be as set forth on the Department's website and §1201.255 of the Standards Act;
 - (4) a list of the components used. If reconditioned components are used the identifying numbers must be legible;

- (5) if installed to manufacturer's instructions, a copy of those instructions, as in effect at the time of installation (one copy on-site is sufficient; a separate copy does not need to be maintained for each installation);
 - (6) if installed to engineer-approved plans (other than manufacturer's instructions or state generic) a copy of the actual plans, showing the Texas engineer's stamp;
 - (7) a copy of any agreement with another party to obtain or provide some or all of the installation services; and
 - (8) a list of all unlicensed individuals who provided installation services under the installer's license, indicating each installation on which they worked.
- (l) An installer shall conspicuously disclose their license number on all advertisements and contracts for installation services.

§80.34. Brokers' Responsibilities and Requirements.
(Effective: November 6, 2011)

- (a) For each transaction where a broker is engaged to provide services, a broker shall retain the disclosure statement set forth on the Department's website.
- (b) For each home sold by a consumer in a brokered sale, the broker shall retain a file for that sale with copies of all required warranties and disclosures, other than a habitability, that would have been given if the sale was through a retailer.

§80.35. Salesperson's Responsibilities and Requirements.
(Effective: December 30, 2007)

- (a) A salesperson may not act in any capacity beyond the scope of a salesperson unless they are legally authorized to do so.
- (b) A salesperson may not collect any monies in connection with a manufactured home transaction except in the name of the sponsoring retailer or broker.

§80.36. Retailers' Rebuilding Responsibilities and Requirements.
(Effective: January 7, 2018)

- (a) Any home that is salvaged as defined in §1201.461 of the Standards Act, may be rebuilt/repared for purposes of issuance of a manufactured Statement of Ownership at the option of the Department after inspection in accordance with Department procedures. Notification in writing to the Department at its Austin headquarters shall be required before rebuilding/repair begins.

- (b) The retailer must:
- (1) notify the Department in writing ten (10) business days before rebuilding (or monthly for continuous activity) and provide the following, if available:
 - (A) HUD or Texas Seal number;
 - (B) data plate and comfort cooling certificate information (applicable wind and roof load zones, manufacturer's name and address, home model, list of appliance models, home production date, thermal zones, transmission coefficients, furnace certification temperatures, and duct capacity for cooling);
 - (C) copy of salvage declaration report if salvaged by an insurance company;
 - (D) description of damage;
 - (E) description of cause of damage (water, wind, impact, fire, etc.); and
 - (F) location of home during rebuilding.
 - (2) provide a plan for rebuilding, sealed by a licensed professional engineer, that contains the following:
 - (A) drawings and specifications that describe the rebuilding;
 - (B) if more than one home is rebuilt in any one (1) month period, then a quality assurance manual that describes the following:
 - (i) system testing;
 - (ii) inspection process of cavities before concealment; and
 - (iii) record keeping.
 - (C) list of new parts and appliances;
 - (D) list of reused or salvaged parts and appliances; and
 - (E) rebuilder's data plate (if applicable).
 - (3) notify the Department when concealed cavities will be exposed for Department inspectors;

- (4) remove damaged material and equipment;
 - (5) add new or used materials and equipment;
 - (6) repair all defects; and
 - (7) repair and test all systems.
- (c) The Department may schedule inspections of the home during the rebuilding process.
- (d) A manufactured home which does not meet the definition of salvage as defined in §1201.461 of the Standards Act, may be refurbished to its original structural configuration so that it is habitable as defined by §1201.453 of the Standards Act.

§80.37. Correction Requirements.
(Effective: April 25, 2010)

- (a) The retailer, installer, or manufacturer shall take immediate corrective action when notification is received from a consumer and the nature of the complaint indicates an imminent safety hazard or serious defect.
- (b) Except as provided in subsection (a) of this section, manufacturers, retailers, and installers shall perform their obligations in accordance with their respective written warranty within a reasonable period of time. A reasonable period of time is deemed to be not more than thirty (30) calendar days following receipt of the consumer's written notification unless there is good cause requiring more time. The consumer's written notification must be given:
- (1) within the one (1) year manufacturer's and retailer's warranty period for new homes;
 - (2) within two (2) years for the installer's warranty period; and
 - (3) for used homes within sixty-five (65) calendar days after the date of the sale or installation, whichever is later.
- (c) The manufacturer, installer, and retailer shall make available for review by Department personnel, records relating to their respective warranty responsibilities, to assure that warranty work has been accomplished and that warranty work has been done in accordance with design or standards criteria and properly completed.

§80.38. Right to Advance Copy of Certain Documents.
(Effective: October 23, 2022)

- (a) A consumer may modify or waive the right to rescind the deadlines for disclosures before the execution of the contract if the consumer determines that the purchase transaction is needed to meet a *bona fide* emergency. To modify or waive the right, the consumer shall give the retailer a dated written statement that describes the emergency, specifically modifies or waives the notice periods, and bears the signature of all the consumers entitled to the disclosures and right of rescission. Printed forms for this purpose are prohibited, except as set forth on the Department's website.
- (b) Printed forms may be used to the rights as provided for in §1201.164 of the Standards Act only if:
 - (1) The basic form set forth on the Department's website is used; and
 - (2) The Director has reviewed and approved the language used to describe the specific declared emergency.
- (c) A retailer or manufacturer may not transfer ownership of a new or used HUD-code manufactured home or otherwise sell, assign, or convey a HUD-code manufactured home to a consumer unless the retailer or manufacturer delivers to the consumer a formaldehyde health notice.
 - (1) The formaldehyde health notice must be delivered before the execution of a mutually binding sales agreement or retail installment sales contract.
 - (2) The formaldehyde health notice will be provided on the Manufactured Housing Division's website. The notice must be of the type, size and format required by the director. A retailer or manufacturer may not vary the content or form of the notice.
 - (3) The formaldehyde health notice may be combined with other disclosures, if deemed appropriate.

SUBCHAPTER D. LICENSING

§80.40. Security Requirements.
(Effective: January 7, 2018)

- (a) For purposes of meeting the security requirements of §1201.105 of the Standards Act, "other security" means a deposit in a state or federally chartered

bank or savings and loan association. If other security is posted, the other security must be maintained in or by a banking institution located in this state subject to a control agreement in the promulgated form set forth on the Department's website. Such deposits are hereinafter referred to as security. If such security is reduced by a claim, the license holder shall, within twenty (20) calendar days, make up the deficit as required by §1201.109(c) of the Standards Act. No advance notice is required by the Department to the license holder, but the Department shall verify the deposit.

- (b) Any other security provided for compliance with §1201.105 of the Standards Act, shall remain in place and subject to a control agreement in favor of the Department for two (2) years after the person ceases doing business as a manufacturer, retailer, broker, or installer, or until such later time as the director may determine that no claims exist against the other security. The Director may consent to the substitution of a bond or a different qualifying deposit for other security provided that in the event a bond is filed to replace the assigned security, the initial effective date of the bond is the same or prior to the date of the assignment of security.
- (c) If a required bond is canceled during the license period, the license shall be automatically suspended on the date bond coverage ceases.
- (d) To be exempt from the additional security as required by §1201.106(b) of the Standards Act, a manufacturer who does not have a manufacturing plant in this state must have a *bona fide* service facility.
 - (1) The manufacturer shall provide the Department with the name, address and phone number of the service facility, conspicuous notice of which shall be provided to each Texas retailer who purchases homes from the manufacturer.
 - (2) The service facility shall be capable of compliance with the provisions of Sub-part I of the Manufactured Housing Improvement Act (latest edition) and capable of providing warranty service within the reasonable time requirements set by the Department in §80.73 of this chapter (relating to Procedures for Handling Consumer Complaints), and shall be subject to periodic review and inspection by Department personnel.
 - (3) If the Department determines that the requirements of paragraph (2) of this subsection have not been met, notice must be sent of that determination and of the requirement of an additional bond amount.
 - (4) Unless additional security is provided as required by the Standards Act, all out of state manufacturers must disclose their in-state service facility on each renewal of their license.

- (e) In order for the Board to direct the Director to stop accepting bonds issued by a surety for reasons outlined in §1201.105(c) of the Standards Act, the Department experiences significant problems if:
 - (1) the surety fails on three (3) or more occasions to make the required reimbursement payment within thirty (30) calendar days from the date of notice from the director that a consumer claim has been paid; or
 - (2) is more than sixty (60) calendar days late in making a required reimbursement payment.
- (f) If the director stops accepting bonds issued by a surety for reasons set forth in subsection (e) of this section, all licensees who are bonded by the affected surety will be notified immediately so they can supply the Department with a new valid bond when they renew their license. If a licensee fails to supply the Department with a new valid bond when they renew their license, their license is automatically suspended until the licensee provides a new valid bond.

§80.41. License Requirements.
(Effective: December 8, 2019)

- (a) General License Requirements. In order to apply to obtain a license, the promulgated form of application for such license must be fully completed and executed and submitted to the Department, accompanied by the required fee, required security, and all other required supporting documentation. The Department may request any reasonably related additional information or documentation to clarify or support any application.
 - (1) Additional provisions applicable to salespersons.
 - (A) A salesperson is an agent of their sponsoring retailer or broker. The sponsoring retailer or broker is liable and responsible for the acts or omissions of a salesperson in connection with any activity subject to the Standards Act or this Chapter. It is a violation of the Standards Act and this chapter for a retailer or broker of manufactured housing to employ a salesperson who is not licensed with the Department or permit them to conduct business subject to the Standards Act on their behalf.
 - (B) If a salesperson's sponsoring retailer or broker is no longer licensed, that salesperson's ability to act and a salesperson is automatically terminated until such time as he or she is acting under a duly licensed sponsoring retailer or broker and such sponsorship is on record with the Department. A salesperson shall surrender his or her license to the Department within ten

- (10) calendar days of termination from his or her sponsoring retailer.
 - (C) A sponsoring retailer or broker shall notify the Department in writing when a salesperson has been terminated or is no longer sponsored by said retailer or broker.
 - (D) A salesperson's sponsoring retailer or broker shall be issued a license card by the Department containing effective date and license number and name and license number of the sponsor. A salesperson shall be required to present a copy of a valid license card upon request.
- (2) Additional provisions applicable to installers.
- (A) A provisional installer's license shall become a full installer's license as outlined in §1201.104(f) of the Standards Act when the Department inspects a minimum of five (5) manufactured home installations and found not to have any identified installation violations.
 - (B) It is the responsibility of an installer who is still on a provisional status to notify the Department of each installation performed promptly. As used in this section, "promptly" means sufficiently early to enable the home to be inspected prior to any skirting being installed, in any event within three business days following the date of completion of the installation.
 - (C) It is the responsibility of the Department's field office to notify the Department's licensing section when a provisional installer's license is eligible for upgrade to a full installer's license.
- (b) Applicable License Holder Ownership Changes.
- (1) A license holder shall not change the location of a licensed business unless the license holder first files with the Department:
 - (A) a written notification of the address of the new location;
 - (B) an endorsement to the bond reflecting the change of location; and
 - (C) the original license.
 - (2) The change of location is not effective until all requirements are received by the Department.

- (3) For a change in ownership of less than fifty percent (50%) of the licensed business entity, no new license is required provided that the existing bond or other security continues in effect. However, the current Articles of Incorporation or Assumed Name Certificate must accompany the request.
 - (4) For a change in ownership of fifty percent (50%) or more, the license holder must file with the Department, along with the appropriate fee and Articles of Incorporation or Assumed Name Certificate:
 - (A) a license addendum by the purchaser providing information as may be required by the Department; and
 - (B) certification by the surety that the bond for the licensed business entity continues in effect after the change in ownership; or
 - (C) an application for a new license along with a new bond or other security and proof that the education requirements of §1201.113 of the Standards Act, have been met.
- (c) Education.
- (1) The Standards Act requirement for an initial eight (8) hour course of instruction in the law, including instruction in consumer protection regulations; four (4) hour retailer education course; and/or four (4) hour installer education course shall be offered quarterly by the Department. Subject to limitations on Department resources, the Department will make special licensing classes available upon written request.
 - (2) Each test to be administered in connection with the course(s) will consist of a representative selection of questions from an approved set of questions approved by the Director. The test(s) will be open-book. A score of 70% correct is required to pass each test.
 - (3) For initial licensing of a salesperson, if the salesperson does not attend and successfully complete the initial licensing class provided by the Department within 90 days after the date of licensure, the license will automatically be suspended until the salesperson has attended and successfully completed that class. While the license is in a suspended status the salesperson may not act as a manufactured housing salesperson.
 - (4) All related persons added to a retailer's license are required to take the initial eight (8) hour course of instruction in the law, including instruction

in consumer protection regulations and the four (4) hour retailer education course prior to being added to the retailer's license.

- (5) All related persons added to an installer's license are required to take the initial eight (8) hour course of instruction in the law, including instruction in consumer protection regulations and the four (4) hour installer education course prior to being added to the installer's license.
- (6) All related persons added to a retailer/installer license or retailer/installer/broker license are required to take the initial eight (8) hour course of instruction in the law, including instruction in consumer protection regulations; the four (4) hour retailer education course; and the four (4) hour installer education course prior to being added to the license.
- (7) All related persons added to a manufacturer's license are required to take the initial eight (8) hour course of instruction in the law, including instruction in consumer protection regulations prior to being added to the manufacturer's license.
- (8) All related persons added to a broker's license are required to take the initial eight (8) hour course of instruction in the law, including instruction in consumer protection regulations prior to being added to the broker's license.

(d) Continuing Education.

- (1) Continuing education program courses must total eight (8) hours and shall include:
 - (A) Continuing education addressing the law and rules with a focus on any revisions to the Code or Rules within the preceding two years.
 - (B) Continuing education addressing the Department's current complaint resolution process.
 - (C) The following additional topics may be covered:
 - (i) installation requirements;
 - (ii) manufactured home financing;
 - (iii) operation of manufactured home parks and communities;
 - (iv) insurance requirements;
 - (v) industry best practices;
 - (vi) business ethics;
 - (vii) topical market statistics or trends; or

- (viii) other subjects determined by the Department to relate directly to the lawful operation of a business subject to the Code.
- (2) Acceptable evidence that the requirements of §1201.113(b) of the Standards Act have been satisfied by the license holder or their related person on record with the Department, would be a certificate, letter, or similar statement provided by the approved education provider indicating that the education program was timely completed. Such evidence may be submitted by fax, mail, e-mail, or in person. All related persons listed on a license are required to complete the eight (8) hours of continuing education required every two years.
- (3) For license renewal, evidence of any required completion, with reference to license number, must be received by the Department before a license may be renewed.
- (4) Approval of courses and providers. In order to be considered for approval by the Board to provide continuing education courses, including prospective continuing education courses in accordance with paragraph (5) of this subsection, a party wishing to be considered for such approval must submit an application, accompanied by the nonrefundable processing fee, and the following:
 - (A) A narrative overview of each course, describing subject matter to be covered;
 - (B) Brief biographies, including credentials of each instructor demonstrating in depth knowledge of the subject matter to be taught;
 - (C) A copy of any course materials to be used. If the course materials are deemed to be proprietary they should be placed in a separate envelope, marked confidential, and accompanied by a written statement as to why they should not be treated as open records. There is no assurance that such materials will ultimately be accorded any exemption from disclosure under the Open Records provisions of the Government Code;
 - (D) A schedule of any fees to be charged for each course;
 - (E) If completion of the continuing education program is limited to any particular group, a description of the limitation;

- (F) As such information becomes available, an indication as to the locations, times, and dates for offerings; and
 - (G) Such other information as the Department may require.
- (5) Prospective continuing education programs, including all portions of education courses, must be pre-approved by the board prior to the course being held or broadcast.
- (6) Once the Department determines that a request for approval is complete, that request will be placed on the next regularly scheduled meeting of the Board for consideration. The Department will provide the board with a written recommendation on each such request. The staff will advise the applicant of the board's action within ten (10) business days of the date of the board meeting, including a written statement as to any limitations, conditions, or other requirements imposed.
- (A) Approvals shall be for a period not to exceed two years. The Department may, at no cost, attend or send a representative to attend any approved portion of the continuing education program to determine that the courses are being taught in accordance with the terms of approval.
 - (B) Should the two-year approval time for a continuing education provider expire in between regularly scheduled board meetings, the executive director may issue approval to continue providing services until the next board meeting upon receipt of the required renewal application, fee, and necessary documentation of education material.
 - (C) The Department may revoke or suspend approval of a continuing education program if the Department determines that any of the courses are not being taught in accordance with the terms of approval or that any of the courses are not being administered in accordance with the law or these rules. Any action to revoke or suspend such an approval is a contested matter under Chapter 2001, Government Code, and the party against whom revocation or suspension is sought may make a written request for a hearing before an Administrative Law Judge. If no such hearing is requested within thirty (30) calendar days after receipt of notice from the Department, the Department order of suspension or revocation shall become final.

- (e) License Application and Renewal.
 - (1) Initial Application Processing.
 - (A) It is the policy of the Department to issue the license within seven (7) business days after receipt of all required information and the following conditions have been met:
 - (i) all required forms are properly executed; and
 - (ii) all requirements of applicable statutes and this Chapter have been met.
 - (B) License applications and accompanying documents found to be incomplete or not properly executed shall be returned to the applicant with an explanation of the specific reason and what information is required to complete license.
 - (C) Upon request, the Department will disclose the license number assigned and the effective date for a license that has been approved but not yet delivered to the license holder.
 - (2) License Renewal Requirements. It is the responsibility of a license holder to renew the license prior to its expiration date.
 - (A) In order to prevent the expiration and lapse of a license, a complete application for license renewal must be received by the Department prior to the date on which the current license expires.
 - (B) If an application for license renewal is received by the Department after the date on which the current license expires, the license will not be issued without the required late fees identified in §1201.116(d) and (e) of the Standards Act.
 - (3) Payment of license fees.
 - (A) All required fees must be paid in order to obtain a valid license, including a renewal license, from the Department.
 - (B) Any license issued by the Department is void and of no effect if based upon a check or other form of payment that is later returned for insufficient funds, closed account, or other reason, regardless of whether the Department notifies the applicant of the insufficiency of payment or the invalidity of the license.

- (C) It is the applicant's responsibility to ensure that all licensing fees are paid in valid U.S. funds.
- (4) Fingerprints and Criminal History Check.
 - (A) License applicants must submit a complete and legible set of fingerprints to a vendor approved by the Department of Public Safety, for the purpose of a criminal background check, which will be provided to the Department.
 - (B) The license applicant shall be responsible for the cost.
- (f) License Application or Renewal Denial.
 - (1) In the evaluation of an applicant for a license, the Director shall consider whether the applicant or any related person involved with the applicant has previously:
 - (A) been found in a final order to have participated in one or more violations of the Standards Act that served as grounds for the suspension or revocation of a license;
 - (B) been found to have engaged in activity subject to the Standards Act without possessing the required license;
 - (C) caused the Manufactured Homeowner Consumer Claims Program to incur unreimbursed payments or claims;
 - (D) failed to abide by the terms of a final order or agreed final order, including the payment of any assessed administrative penalties; or
 - (E) had any state license revoked for violations of a law or rule.
 - (2) If any of the preceding factors is present with respect to the applicant or any related person involved with the applicant, the director will further determine:
 - (A) whether all appropriate corrective action has been taken;
 - (B) whether the applicant has adopted policies and procedures or taken other appropriate measures to prevent recurrences; and
 - (C) whether additional conditions or limitations on the license would be appropriate.

- (3) In determining whether an applicant should be issued a license if that applicant states in his/her application for said license that he/she has a criminal record, which may include a conviction, deferred adjudication, plead guilty, or nolo contendere for any felony or misdemeanor offense, other than a Class C Misdemeanor for traffic violations, within five (5) years preceding the date of the application, the Director shall consider the factors set out in Texas Occupations Code, §53.022:
- (A) the nature and seriousness of the crime;
 - (B) the relationship of the crime to the intended manufactured housing business activity;
 - (C) the extent to which a license holder might engage in further criminal activity of the same or similar type as that in which the applicant previously had been involved;
 - (D) the relationship of the crime to the ability, capacity, or fitness required to perform the duties and discharge the functions and responsibilities of the license holder's occupation or industry; and
 - (E) whether the offenses were defined as crimes of moral turpitude by statute or common law, from Class A misdemeanors to first, second, and third degree felonies carrying fines and/or imprisonment or both. Special emphasis shall be given to the crimes of robbery, burglary, theft, embezzlement, sexual assault, and conversion.
- (4) In addition to the factors that may be considered in paragraph (3) of this subsection, the Department, in determining the present fitness of a person who has a criminal record, may consider the following:
- (A) the extended nature of the person's past criminal activity;
 - (B) the age of the person at the time of the commission of the crime;
 - (C) the amount of time that has elapsed since the person's last criminal record;
 - (D) the conduct and work activity of the person prior to and following the criminal record; and
 - (E) evidence of the person's rehabilitation or attempted rehabilitation effort while incarcerated or following release.

- (5) The applicant shall furnish proof in any form, as may be required by the Department, that he/she has maintained a record of steady employment and has otherwise maintained a record of good conduct and has paid all outstanding court costs, supervision fees, fines, and restitution as may have been ordered in all criminal cases.
- (6) If the Department suspends or revokes a valid license, or denies a person a license or the opportunity to be considered for a license in accordance with this subsection because of the person's prior criminal record and the relationship of the crime to the license, the Department shall:
 - (A) notify the person in writing stating reasons for the suspension, revocation, denial, or disqualification; and
 - (B) offer the person the opportunity for a hearing on the record. If the person does not request a hearing on the matter within thirty (30) calendar days from receipt of the Department's decision, the suspension, revocation, or denial becomes final.
- (g) Exemption for Retailer's License Requirement.
 - (1) Application for Exemption of Retailer's License Requirement.
 - (A) A person requesting exemption from the Retailer's licensing requirement of §1201.101(b) of the Occupations Code, shall submit the required application outlining the circumstances under which they are requesting exemption from licensure.
 - (B) Applications should identify the HUD label or serial number(s) of up to three (3) homes being sold under the exemption;
 - (C) Applications will be processed within seven (7) business days after receipt of all required information.
 - (2) The circumstances under which this exemption is granted are:
 - (A) One-time sale of up to three (3) manufactured homes in a 12-month period as personal property;
 - (B) Non-profit entity transferring ownership of up to three (3) manufactured homes in a 12-month period; and/or
 - (C) No other manufactured homes have been purchased and resold in the previous twelve (12) months, even with a previous exemption.

- (3) Letter of Exemption.
 - (A) Once granted, a Letter of Exemption from licensure will be issued by the Executive Director to the applicant.
 - (B) Letter of Exemption is valid only for the manufactured home(s) specified.
 - (C) Letter of Exemption is valid only for twelve (12) months.
 - (D) The homes may not be sold until the Letter of Exemption is granted.

SUBCHAPTER E. ENFORCEMENT

§80.70. Enforcement.
(Effective: March 25, 2012)

- (a) A licensee shall not obstruct or hinder any inspection, investigation, or enforcement efforts being carried out by the Department.
- (b) Subpoenas or any other order issued by the Director may be served by any person acting on behalf of the Director.

§80.71. Rules for Hearings.
(Effective: May 15, 2016)

- (a) Unless otherwise expressly set forth in the Standards Act or this chapter, all hearings shall be held and conducted pursuant to the applicable provisions of Government Code, Chapter 2001.
- (b) Any party to a hearing may request that a record of the hearing be made and transcribed by an independent court reporter, other than an employee of the Department. Such request must be made not later than seven (7) calendar days prior to the hearing. The additional cost and expense of the independent court reporter may be assessed against the party making the request.
- (c) Notice of a hearing shall specify all state and federal laws, rules, and regulations, including but not limited to, if applicable, HUD regulations, that the Department believes are relevant to any issue to be involved in the hearing.
- (d) The Department may serve the notice of hearing on the respondent at his or her last known address as shown by the Department's records.

- (e) If, after receiving notice of a hearing, a party fails to appear in person or by representative on the day and time set for hearing or fails to appear by telephone in accordance with Government Code, Chapter 2001, also known as the Administrative Procedures Act, the hearing may proceed in that party's absence and a proposal for decision may be entered by default, accepting all facts and conclusions of law as deemed admitted.
- (f) If the administrative law judge grants a default but does not issue a default proposal for decision and instead issues a default order dismissing the case and returning the file to the Department for informal disposition on a default basis in accordance with §2001.056 of the Texas Government Code, the Executive Director may issue a final order deeming the allegations in the Notice of Hearing as true.
- (g) Pursuant to the Administrative Procedures Act, each party has the right to file exceptions to the Proposal for Decision and present a brief with respect to the exceptions. All exceptions must be filed with the Department within ten (10) business days of the Proposal for Decision, with replies to be filed ten (10) business days after the filing of exceptions.
- (h) When an administrative hearing is held for any matter in which the Department seeks to take action against a licensee for violating the Standards Act or these rules, whether such action is an action to assess administrative penalties, to require corrective action, to require cessation of improper activities, to suspend or revoke a license, or any combination thereof, the Department shall assess the costs of the proceeding against any party that fails to appear at a duly noticed administrative hearing. The costs assessed shall be the greater of \$100 or the actual costs charged to the Department by the State Office of Administrative Hearings, the Office of the Attorney General, any court reporter, or any other third party providing services in connection with such hearing.
- (i) The Department will seek the recovery of its costs from any party against whom it initiates an action if that action results in the entry of a final order taking any administrative action against that party, including the assessment of administrative penalties, requiring corrective action, requiring cessation of improper activities, suspension or revocation of a license, or any combination thereof.

§80.72. Sanctions and Penalties.
(Effective: March 25, 2012)

- (a) In accordance with the provisions of §1201.605 of the Standards Act, the Director may assess and enforce penalties and sanctions against a person who violates any applicable law, rule, regulation, or administrative order of the Department.

- (b) The determination of any penalties or other sanctions to be assessed shall be based on the consideration of statutory factors and whether the person against whom such penalties and/or sanctions are to be assessed has timely and in good faith taken the necessary steps to achieve, to the extent feasible, full compliance with all applicable state and federal laws, rules, and regulations and taken appropriate measures to prevent future violations.
- (c) When a licensee first receives written notification of a claim for warranty service, the licensee must respond promptly to the request. A failure to do so shall constitute a violation of this chapter.
- (d) Immediate corrective action is required if the matter involves an imminent safety hazard.
- (e) If, after reasonable investigation, a licensee disputes whether warranty service is required and the licensee is unable to resolve the matter by agreement with the consumer, the licensee may request that the Department perform an inspection of the home. The running of the time to respond to the request for warranty service will be suspended from the time the request for inspection is received until the Department performs the inspection and issues its findings. When the Department concludes its review it will work with the affected licensee(s) and consumer(s) to agree upon a reasonable time to address its findings. In the event the parties cannot agree on a reasonable time, the Director shall issue a revised order assigning a time for compliance. An agreed or ordered time to respond to a request for warranty service may be extended by the Director in response to a request setting forth good cause for the extension. Any such request must be made to the Director prior to the expiration of the allotted time for response. Requests may be made by U.S. First Class mail, by FAX, or by e-mail, or, if followed with written confirmation sent U.S. First Class mail, or by telephone.
- (f) Any and all penalties are IN ADDITION to full compliance with the Standards Act and Rules (*i.e.*, full, prompt corrective action, restitution, or whatever else the Standards Act and rules would have required in the first place). Failure to provide such compliance on a timely basis, as specified in the applicable order, will be deemed to be a violation of the order and serve as a basis for pursuing additional administrative action, including the assessing of additional penalties and the pursuit of suspension or revocation of licenses.
- (g) The Department offers, at no charge, alternative dispute resolution as an inexpensive and informal way of attempting to resolve any claim or dispute. Depending on the parties, this may involve informal meetings or non-binding mediation. Alternative dispute resolution is available upon request. In the event that a disputed matter cannot be resolved in this manner, the Department

reserves the right to pursue all other lawful means of resolution including, but not limited to, pursuit of administrative remedies.

§80.73. Procedures for Handling Consumer Complaints.
(Effective: December 8, 2019)

- (a) A complaint may be initiated by a consumer or by the Department. Unless the Department determines that it is appropriate to proceed in another manner a copy of the complaint will be provided to each person involved. The letter shall request a written response within ten (10) calendar days unless the Department determines that a longer or shorter period is warranted.
 - (1) If the consumer has not previously notified the manufacturer, retailer or installer, the Department will forward the written notification to the manufacturer, retailer, or installer. This will constitute written notice of a request for warranty service.
 - (2) If the consumer has previously provided written notification to the manufacturer, retailer or installer of the need for warranty service or repairs, but believes such has not been completed in a satisfactory manner, the Department shall perform a home inspection, if required. If a home inspection is performed and violations are found, the Department will assign responsibilities for repair, and notify the manufacturer, retailer, installer, and consumer of their responsibilities to complete such warranty or service repair in accordance with §1201.356(c) of the Standards Act.
- (b) The Department shall make a consumer complaint home inspection upon request.
 - (1) Consumer Request. The consumer may, at any time, request that the Department perform a consumer complaint home inspection. A written complaint regarding failure to provide warranty work is deemed to be a request for a consumer complaint inspection. No written complaint form is required if a possible imminent safety hazard exists.
 - (2) Industry Request. Manufacturer or retailer requests for a consumer complaint home inspection must be signed, shall identify the home by HUD label and serial number(s), and shall provide the necessary information for the Department to contact the consumer and determine the physical location of the home. The manufacturer or retailer may request a consumer complaint home inspection if the manufacturer or retailer:

- (A) believes that the consumer's complaints are not covered by the respective written warranty, or implied warranties;
 - (B) believes that the warranty service was previously properly provided; or
 - (C) has a dispute as to the respective responsibilities pursuant to the warranties.
- (3) All complaints transferred to the field shall be inspected within 30 calendar days from the date the verified complaint was received. A complaint is deemed verified once it is established that the Department has jurisdiction over the matter.
- (A) The consumer, manufacturer, retailer, and installer, as applicable, shall be notified of the scheduled inspection.
 - (B) The person conducting the inspection shall inspect all matters (relating to the home and/or the installation of the home) set forth in the complaint and any other items raised at the inspection.
 - (C) The person conducting the inspection will issue a report of inspection, completed to reflect the findings of the inspection.
- (c) The retailer, installer, or manufacturer shall take immediate corrective action when notification is received from a consumer and the nature of the complaint indicates an imminent safety hazard or serious defect.
- (d) Except as provided in subsection (c) of this section, manufacturers, retailers, and installers shall perform their obligations in accordance with any assigned order for corrective action pursuant to §1201.356(c) of the Standards Act within a reasonable period of time. A reasonable period of time is deemed to be thirty (30) calendar days following receipt of the order from the Department unless there is good cause requiring more time.
- (e) When service or repairs are completed following any notice or orders from the Department pursuant to §1201.356(a) of the Standards Act, the manufacturer, retailer, and/or installer shall forward to the Department copies of service or work orders reflecting the date the work was completed, or other documentation to establish that the warranty service or repairs have been completed. A consumer is not required to sign the service or work order. These service or work orders must be received by the Department no later than five (5) calendar days from the expiration of the period of time specified in the warranty

order issued by the Department. Corrective action taken is subject to re-inspection.

- (f) If service or repairs cannot be made within the specified time frame, the license holder shall notify the Department in writing prior to the expiration of the specified time on the warranty order. The notice shall list those items which have been, or will be, completed within the time frame and shall show good cause why the remainder of the service or repairs cannot be made within the specified time frame. The license holder shall request an extension for a specific time. Original deadline to complete warranty work may apply if the request for extension is denied. If the Department fails to respond in writing to the request within five (5) business days of the date of receipt of the notice of request for extension, the extension has been granted.
- (g) Once the Department receives the service or work orders confirming that all assigned items have been addressed and the Department has, to the extent deemed necessary or appropriate, inspected the work, a complaint will be closed.
- (h) A complaint may be reopened for good cause upon the approval of the Director or his or her designee(s).
- (i) If a purchaser of a manufactured home for business use has proof that they disclosed to the retailer in writing at the time of purchase that the purchaser intended for a person to be present in the home for regularly scheduled work shifts of not less than eight (8) hours prior to purchasing a manufactured home for business use they may file a complaint with the Department if the manufactured home is not habitable.
 - (1) The complaint must be filed in writing to the Department within sixty (60) days of the later of the date of sale or the date of installation.
 - (2) The retailer is required to make the home habitable if after a Department inspection it is determined to be inhabitable and the proper evidence was submitted demonstrating the intended business use of the manufactured home.

SUBCHAPTER F. MANUFACTURED HOMEOWNER CONSUMER CLAIMS PROGRAM

**§80.80. Administration of Claims under the Manufactured Homeowner Consumer Claims Program.
(Effective: January 7, 2018)**

- (a) The Director, before authorizing any party performing warranty work or providing other goods or services that are to be reimbursed from the

Manufactured Homeowner Consumer Claims Program (the “Claims Program”) to proceed, will require that an estimate be submitted on the form set forth on the Department's website properly completed and executed.

- (b) Re-assigned warranty work required by the Director to be performed shall, unless extended for good cause or provided otherwise in the order, be performed within thirty (30) days or such other time as the director may by order specify:
 - (1) evidence that re-assigned warranty work was performed shall, unless extended for good cause, be supplied to the Department within ten (10) days of completion; and
 - (2) all warranty work or other work to be reimbursed from the Claims Program, once completed, is subject to being re-inspected.
- (c) An order re-assigning warranty work and designating the party responsible for the re-assigned warranty work as a “consumer” under §1201.358(d) of the Standards Act becomes final if not appealed within thirty (30) days.
- (d) Failure to provide a required estimate in connection with an order to perform re-assigned warranty work, once that order has become final, may serve as grounds for an administrative action against the licensee.
- (e) When a consumer has a covered claim against a licensee and the licensee has not satisfied the claim, the Department shall take appropriate steps to make sure that the claim is proper, meeting all requirements of laws and rules, and that all reasonable steps to satisfy the claim have been exhausted. If the damages arose as a result of a violation of the Texas Deceptive Trade Practice – Consumer Protection Act, the specific violation must be adequately documented. Acceptable documentation would include a court order finding that such a violation had occurred or the establishing of confirmed facts that would specifically constitute such a violation, along with proof that the court order could not be satisfied. The specific violation must relate directly to the manufactured home or the sale transaction regarding the manufactured home.
- (f) Once a payment is made from the Claims Program, the Department shall file a claim under the bond of or deduct the amount paid from other security provided by the party primarily responsible for the unsatisfied claim.

SUBCHAPTER G. STATEMENTS OF OWNERSHIP

§80.90. Issuance of Statements of Ownership.
(Effective: January 7, 2018)

- (a) Application Requirements. In order to be deemed complete, an application for a Statement of Ownership must include, as applicable:
 - (1) A completed and fully executed Application for Statement of Ownership on the Department's prescribed current form
 - (2) The required fee;
 - (3) If the statement of ownership is to reflect the recordation of a lien, other than a tax lien, for which the Department does not have the owner's consent, copies of documentation establishing the creation and existence of each such lien, and an affidavit of fact explaining the circumstances of the lien;
 - (4) When one or more existing liens are to be released, assigned, or foreclosed, appropriate supporting documentation;
 - (5) When an application for Statement of Ownership indicates a change in ownership but no change in lien, supporting documentation that clearly establishes that the lien holder consented to that change; and
 - (6) When a manufactured home is to be designated for use as a dwelling and/or personal property after the home has been designated for business use, salvage, or as real property, evidence of a satisfactory habitability inspection by the Department.
- (b) Right of Survivorship: If a right of survivorship election is made, then the Department will issue a new Statement of Ownership to the surviving person(s) upon receipt of a copy of the death certificate of the deceased person(s), a properly executed application for Statement of Ownership, and the applicable fee.
- (c) Corrections to Statements of Ownership.
 - (1) If a correction is required as a result of a Department error, it will be corrected at no charge.

- (2) If a correction is requested because of an error made by a party other than the Department, the correction will not be made until the Department receives the following:
 - (A) A complete corrected application for Statement of Ownership, or
 - (B) Documentation deemed appropriate and approved by the Executive Director, pursuant to §1201.207(c) of the Standards Act.
- (d) Upon issuance of a Statement of Ownership, the Department will mail one copy to the owner and one copy to the lienholder. If an additional copy is desired for a third party it should be noted on the application with appropriate mailing information.
- (e) Exchanging a Document of Title or certificate of attachment for a Statement of Ownership: The Department will issue a Statement of Ownership, with no change in status, to replace a title or certificate of attachment at no charge upon receipt of the original title or certificate of attachment and the physical location of the home. If a manufactured home title showed that it was personal property, that will be presumed to be its status until and unless a revised Statement of Ownership is applied for and issued. Likewise, if a manufactured home has had a certificate of attachment issued and had title cancelled to real property, that shall be presumed to be its status until and unless a revised Statement of Ownership is applied for and issued.
- (f) Updating of Statements of Ownership on Manufactured Homes Transferred as Real Property.
 - (1) When a manufactured home has become real property because the owner completed the conversion process required by the Standards Act, the home may be sold, transferred, or encumbered as real property by the customary means used for real property transactions. As long as the home remains real property at the same location, ownership of the home is confirmed in the same manner as any other real property, rather than by verifying Department records. A new Statement of Ownership does not have to be applied for until and unless:
 - (A) the home is moved from the location specified on the statement of ownership;
 - (B) the current owner of the manufactured home wishes to convert it to personal property status;
 - (C) the use of the property is changed to business use or salvaged; or

- (D) the manufactured home no longer meets the requirements to be classified as real property (such as the home being on property subject to a long term lease which is not assignable to the buyer or transferee).
- (2) To convert a manufactured home from real property to personal property, the owner of the home must submit a completed Application for Statement of Ownership to the Department with supporting documentation as follows:
- (A) If the applicant is not the owner of record with the Department, satisfactory proof of ownership under a complete chain of title. Acceptable evidence would include, but not be limited to, authenticated copies of all intervening transfer documents, a court order confirming ownership, or title insurance policy in such owner's name issued by a title insurance company licensed to do business in Texas.
 - (B) Satisfactory evidence that any liens on the manufactured home have been discharged or that all lienholders have consented to the change.
 - (C) Evidence of either a satisfactory habitability inspection by the Department or an election to convert the status of the home to business use or salvage.
 - (D) For the purposes of subparagraph (B) of this paragraph, the Department may rely on a commitment for title insurance, a title insurance policy, or a lawyer's title opinion to determine that any liens on real property have been released.
- (3) To update the ownership on a manufactured home already elected and perfected as real property, and remaining in the same location as real property, the new owner of the home must submit a completed Application for Statement of Ownership to the Department with supporting documentation as follows:
- (A) If the applicant is not the owner of record with the Department, satisfactory proof of ownership under a complete chain of title. Acceptable evidence would include, but not be limited to, authenticated copies of all intervening transfer documents, a court order confirming ownership, or title insurance policy in such owner's name issued by a title insurance company licensed to do business in Texas.

- (B) Satisfactory evidence that any liens on the manufactured home have been discharged or that all lienholders have consented to the change.
 - (C) For the purposes of subparagraph (B) of this paragraph, the Department may rely on a commitment for title insurance, a title insurance policy, or a lawyer's title opinion to determine that any liens on real property have been released.
- (4) When a home is being converted to real property, a copy stamped "filed" by the county must be submitted to the Department as evidence that the requirements of §1201.2055 of the Standards Act have been satisfied and the real property election has been perfected. This must be done within sixty (60) days from the issuance date reflected on the Statement of Ownership.
- (g) When a title company or attorney's office fails to complete the conversion of a manufactured home to real property, the holder or servicer of the loan may apply for a statement of ownership electing real property status after-the-fact, providing that evidence of notice to all parties is sent via certified mail and that proof of such efforts is provided along with an affidavit of fact describing such efforts, pursuant to §1201.2055(i)(3) of the Standards Act.
- (h) Submitting an application for Statement of Ownership pursuant to the abandonment provision in §1201.217 of the Standards Act, should include an affidavit of fact, on the prescribed form, attesting to that all statutory notifications have been made to the appropriate parties, including the tax assessor-collector of the county where the home is located, and evidence that all notification was sent via certified mail.
- (i) A Priority Handling Service may be offered by the Department for an additional fee of \$55, each time an application for statement of ownership is reviewed on a priority basis, whether the application is complete or incomplete. Initial or resubmitted applications submitted with priority handling requested and including the additional fee, will be processed within five working days from the date the application is recognized as received in the Department (applications received after 3:30 p.m. become part of the following day's mail).
 - (1) If the application is received complete, a Statement of Ownership will be issued and mailed within the established time.
 - (2) If the application is received incomplete, a Request for Additional Information will be issued and mailed within the established time.

- (3) Applications requiring habitability or salvage rebuilding inspections are not eligible for the Priority Handling Service.
- (j) When it is deemed appropriate by the executive director, an affidavit of fact may be required as additional documentation to accompany a statement of ownership application.

§80.91. Issuance of a Texas Seal.
(Effective: January 7, 2018)

- (a) Issuance of a Texas Seal requires the submittal of an application for Statement of Ownership, the applicable fee and the fee for each Texas Seal issued.
- (b) A Texas Seal can only be issued to a home meeting the definition of a HUD Code manufactured home or a mobile home.

§80.92. Inventory Finance Liens.
(Effective: March 25, 2012)

- (a) A lien and security interest on manufactured homes in the inventory of a retailer, as well as to any proceeds of the sale of those homes, is perfected by filing an inventory finance security form approved by this Department and in compliance with these sections. The required form is set forth on the Department's website.
- (b) A separate form must be filed for each licensed sales location and must include a summary of homes by label or serial number, that are secured with the form.

§80.93. Recording Tax Liens on Manufactured Homes.
(Effective: November 23, 2014)

- (a) Manually filed tax liens shall be filed with the Department using the form set forth on the Department's website. No other form will be accepted for the manual filing of tax liens. The form must be properly completed.
- (b) Electronically filed tax liens and tax lien releases shall be filed with the Department using the required format as provided in the Tax Lien File Layout set forth on the Department's website. No other format will be accepted for electronic filing of tax liens.
- (c) When releasing a tax lien recorded with the Department via a tax certificate or tax paid receipt, the documentation must demonstrate the tax lien field has been satisfied for the correct home.
- (d) For tax liens recorded after June 18, 2005, but prior to the rules that were effective on January 29, 2006, those tax liens relating to tax years prior to 2001 were disregarded and will not be treated as having been recorded.

- (e) A tax collector may file as a central tax collector under a single taxing entity ID number, in which case the liens recorded or released under that taxing entity ID number will extend to all liens created for tax obligations to the taxing entity for which the filer collects. In order, however, to file as a central collector, the filer must complete and provide to the Department the form set forth on the Department's website. A single filing for multiple taxing entities must reflect the aggregate amount of the tax liabilities to which the filing relates.

§80.94. Report to County Tax Assessor-Collectors and County Appraisal Districts.
(Effective: March 25, 2012)

In order to comply with §1201.220 of the Standards Act, which requires the Department to provide a monthly report to each tax assessor-collector and county appraisal district in Texas, the Department will provide the required information by hardcopy or electronically, when possible. Section 1201.009 of the Standards Act, allows the Department, if feasible, to perform any action under this chapter by electronic means.

§80.95. Recording Ownership for Emergency Housing.
(Effective: December 8, 2019)

- (a) A federal government agency that purchases a manufactured home to provide temporary housing in response to a natural disaster or other declared emergency may apply for a statement of ownership using the Statement of Ownership Application for Federal Governmental Agency.
- (b) The Department may also accept a Certificate to Obtain Title signed by the federal government agency or their authorized representative in lieu of the Statement of Ownership Application for Federal Governmental Agency.
- (c) The Department shall apply priority and special handling when an application for emergency housing in conjunction with a natural disaster or declared emergency is received.
- (d) The Department may waive or refund any fees for emergency housing affiliated with a governor's executive order or proclamation that declares a state of disaster under Chapter 418 of the Government Code in the affected area.